

2024 — 2025

new perspectives



furniture
lighting
accessories

on
scandinavian
design

MUUTO



New Perspectives

Creating Spaces That Feel Just Right	4
Inside With — Eve Wilson	46
Our Sustainable Perspectives	74

Collection 76

Furniture	77
Chairs & Stools	78
Sofas & Lounge Chairs	92
Tables	103
Outdoor	110
Shelving & Storage	115
Lighting	121
Pendant Lamps	122
Table Lamps	126
Wall Lamps	130
Floor Lamps	134
Accessories	136
Hangers & Mirrors	137
Storage & Office	140
Vases & Kitchen	142
Rugs & Cushions	143
Find out More	144

Connect Soft Sofa 2-Seater Config. 2 p. 94
Upholstered in Hearth 8

Fine Suspension Lamp 90 cm p. 125

Soft Coffee Table p. 107
Relevo Rug p. 143



new perspectives on scandinavian design

Muuto is rooted in the Scandinavian design tradition characterized by enduring aesthetics, functionality, craftsmanship and an honest expression. By expanding this heritage with forward-looking materials, techniques and bold creative thinking, our ambition is to deliver new perspectives on Scandinavian design.

In fact our name, Muuto, comes from muutos, meaning new perspective in Finnish. We handpick leading contemporary designers who are strong interpreters of our philosophy and combine their talents with the passionate Muuto creative team.

You will know our design because it has muutos: objects made sublime through new perspectives, enjoyed across the world, representing the best of Scandinavian design today.



creating
spaces
that feel

just right

“When you have heightened
aesthetic experiences...
They change you.
They change your biology.
They change your mood.
They change your emotion”

—Susan Magsamen



—at home

“Neuroaesthetic research has allowed us to identify a myriad of factors that contribute to a sense of well-being: *color, form, light, the presence of nature, and tactile materials* that speak to our senses, easily applicable and combined for the optimal atmosphere at home.”

Exploring new perspectives on Scandinavian design is key to Muuto’s forward-looking, innovative designs. Intuitively knowing that design has the capacity to greatly affect the way we feel, we continue to believe in the importance of creating intentional atmospheres through a thoughtful selection of furniture, lighting, and accessories.

Intuitively, we all know the feeling of entering a room and immediately feeling at ease or stimulated. That interacting with elements of design—be it sensations of light, color, or texture—can trigger emotions and spark a dynamic interplay of neurotransmitters in our brains. This process can shape our feelings, thinking and behavior. There is more to design than meets the eye.

The Impact of Neuroaesthetics on Design and Spaces

Neuroaesthetics is about mind-body connection: a scientific discipline that explores and measures how creative expression makes an impact on us. It gives a deeper understanding of the way art, design, and architecture activate our senses and stimulate our sense of well-being. Understanding how we respond to different spaces allows us to better discern the connection between body, mind, and design.

Through our longstanding collaboration with Susan Magsamen, executive director of the International Arts + Mind Lab at Johns Hopkins University, we continuously explore how to be intentional in shaping the spaces we create.

How to Create Intentional Spaces for the Home

Neuroaesthetic research has allowed us to identify a myriad of factors that contribute to a sense of well-being. We continue to explore, experiment with and consciously incorporate these into our interiors, creating spaces that feel just right. Among them are five elements that seem to significantly affect us all: color, form, light, the presence of nature, and tactile materials that speak to our senses, easily applicable and combined for the optimal atmosphere at home.

Combining the 5 Principles

We know that COLOR deeply affects our mood in a space, helping us feel relaxed or energized. Meanwhile, we seem to be intuitively drawn to rounded FORMS rather than angular, such as the curved armrest of a lounge chair. Similarly, using TACTILE MATERIALS like a textile you like to run your fingers over and surfaces that speak to our sense of touch draws us in and creates a pleasant sensation.



Introducing NATURE to our interiors through natural elements like greenery and fresh cut flowers and materials such as wood, wool textiles, ceramics, or clay into our homes has been demonstrated to lower stress levels, promote feelings of calmness, lower our cortisol levels, and promotes well-being. Our circadian rhythm is greatly impacted by both natural and artificial LIGHT. The amount of light, the light temperature, and when we are exposed to light, among other things, all play into whether we feel at ease or more alert and focused. For instance, a task light on your home desk can help you stay focused and productive by providing bright, concentrated illumination for your work area. Meanwhile, ambient lighting fosters tranquility and relaxation in our bedroom, enveloping the space in a gentle, soothing glow.



We hope our perspectives on Scandinavian design will inspire you to reflect on your surroundings. As you browse through this catalog, let our pictures and words inspire you—and encourage you to create spaces that feel just right for you. •

Flow Trolley p. 120
Ply Rug p. 143

70/70 Table 255x108 cm p. 104
Strand Pendant Lamp Ø60 closed p. 122

Fiber Soft Armchair Tube Base p. 81
Upholstered in Ecriture 710 / Grey



Its interior shell, made of 100% recycled plastic, is clad with soft wadding and upholstery to elevate a supreme sense of ease and embrace. The spacious, ultra-soft seat and smooth curves of the Fiber Soft Armchair provide maximum comfort.

fiber soft armchair





A mirror with a charming window-like allure that brings forth the *natural character* and grain of the spruce wood.



Leaf Floor Lamp p. 135
Pebble Rug p. 143

Couple Coffee Table p. 108
Soft Side Table p. 109

In Situ Modular Sofa Corner Config. 4 p. 96
Upholstered in Clay 12

“The idea for the Ridge Vase came while traveling through different cities with a vase in mind, searching for details that had an architectural feel.”

— Studio Kaksikko



Ridge Vase p. 142





Evolving with your needs,
 the Stacked Storage System can
 be arranged and rearranged for
 the exact configuration that you'd
 like, whether it be as bookcases,
 sideboards, or bedside tables.

Relevo Rug p. 143

Couple Coffee Table p. 108
Ridge Vase p. 142

Connect Soft Modular Sofa 3-Seater p. 94
Upholstered in Grace Leather Cognac







Kink Vase p. 142

Restore Basket p. 140
Workshop Coffee Table p. 108



Fiber Side Chair Swivel Base p. 84
Upholstered In Acca 961 / Grey

Workshop Table p. 106
Dedicate Table Lamp S2 p. 130

Arrange Desktop Series p. 141
Reduce Paper Bin p. 141

The 7o/7o Outdoor Table is designed with a simple expression, paired with subtle, understated details that reveal themselves upon closer inspection. Available with FSC™-certified (FSC-Co28824) Sapele Mahogany, a durable hardwood resistant to the wear and tear of being outdoors.



Ease Portable Lamp p. 128

Raise Carafe & Glasses p. 142
Silent Vase p. 142

Fiber Outdoor Side Chair p. 114
7o/7o Outdoor Table p. 114



7o/7o outdoor

table



Mere Bowl p. 142
Kink Vase p. 142

7o/7o Outdoor Table p. 114
Fiber Outdoor Armchair p. 114





Raise Carafe & Glasses p. 142
Piton Portable Lamp p. 128

Linear Steel Lounge Armchair p. 113
Linear Steel Coffee Table p. 111

The Linear Steel Armchair is designed with clean, elegant lines and subtle details for a modern expression. Uniting inviting *organic shapes with extensive comfort* and long-lasting qualities, the Linear Steel Armchair is an outdoor chair without compromise.



Raise Carafe & Glasses p. 146

Linear Steel Armchair p. 112
Linear Steel Table p. 111



Linear Steel Bench p. 112
Top Pendant Lamp Ø21 p. 123

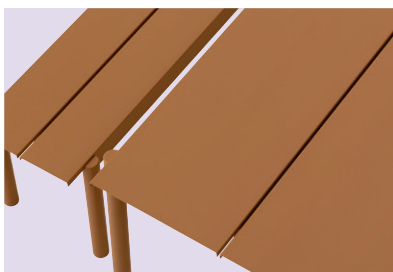

“Relevo means relief in Latin, emblematic of the rug’s *geometric pattern*, made by trimming the *hand tufted* rug in levels and thereby creating a subtle effect of light and shadow.”

— Studiopepe

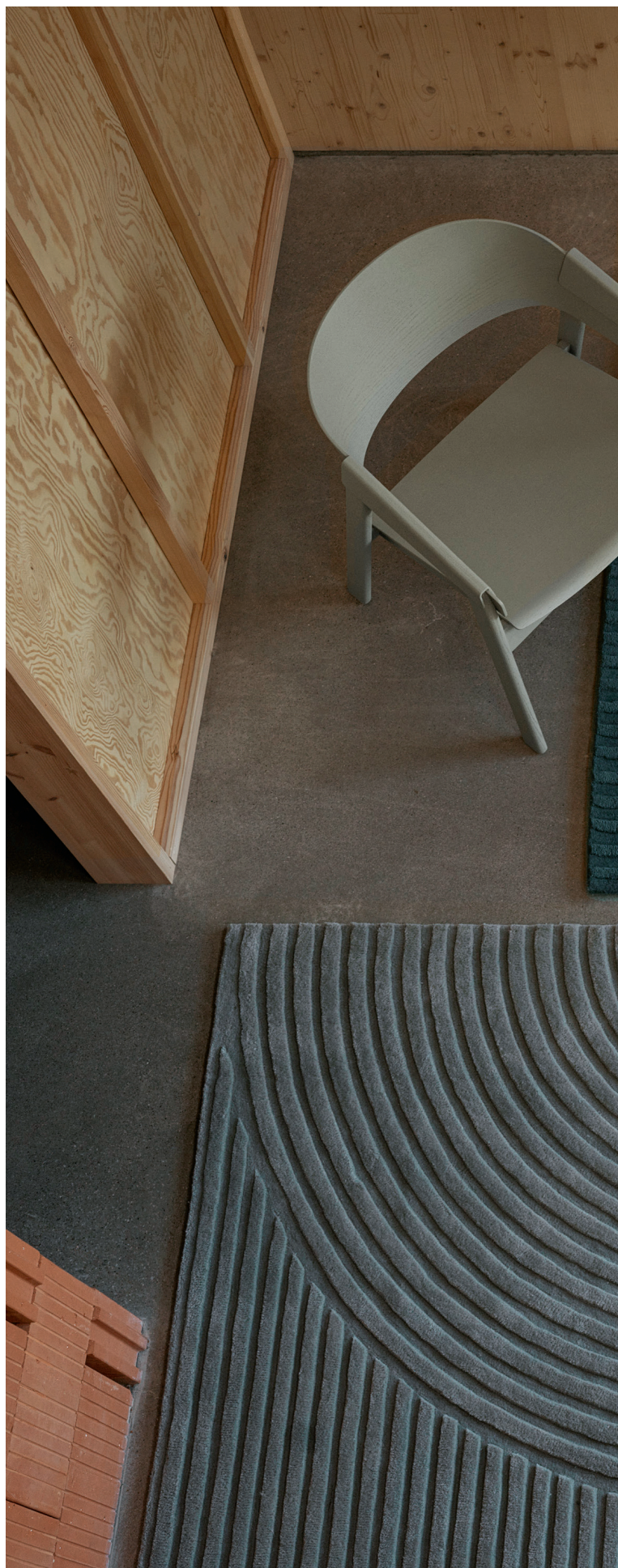



Strand Pendant Lamp Ø80 p. 122

Earnest Extendable Table 205 cm p. 105
Raise Carafe & Glasses p. 142

Fiber Soft Armchair Tube Base p. 81
Upholstered in Hearth 8



“It is nice to have a project made in one material, there is an honesty to that. It is made in one place. One material, one process. In the spirit of that simplicity, I have tried to pare back and refine, to reduce the table to its most essential elements.”

— John Tree

“With its cloud-like appearance, the Strand Pendant Lamp is designed in a unique cocoon material that filters light through for a comfortable glow.”

— Benjamin Hubert

strand



Strand Pendant Lamp p. 122

pendant

lamp

Referencing architectural shapes, the Outline Sofa adds new perspectives to the classic Scandinavian design sofas of the 1960's, marrying the ideals of *simplicity* and function.





Post Floor Lamp p. 134
Kink Vase p. 142

Relevo Rug p. 143
Couple Coffee Table p. 108

Outline Sofa 3-Seater p. 93
Upholstered in Refined Leather Cognac



Fiber Lounge Armchair Tube Base p. 101
Upholstered in Ecriture 910/Grey

In Situ Modular Sofa 3-Seater Config. 4 p. 96
Upholstered in Acca 121

Couple Coffee Table p. 108
Soft Side Table p. 108



The Fiber Lounge Armchair features a spacious seat and embracing curves that embody the elegance of the Fiber Series in a softer, more inviting form.

A contemporary take on the classic architect lamp, where design meets functionality seamlessly. Meticulously engineered, the lamp offers integrated cooling ribs, quality lighting, dimming, and an auto-turn-off feature — while guaranteeing steadiness through its flexible arms.

dedicate table lamp





Set Table Lamp p. 196

Stacked Storage System
— Sideboard Config. 3 p. 116

Framed Mirror p. 139

Ease Portable Lamp p. 128
Mini Stacked Storage System p. 118

Dots Wood Coat Hooks p. 137
Left Chair p. 86



A natural focal point of the home, the Midst Table is a generous, round dining table where friends and family gather — and there is always room to squeeze in one more guest. Its *refined silhouette* is simple yet characteristic, enhanced by distinct detailing and *contrasting materiality*.



Inspired by the traditional tile table, the Couple Coffee Table is a refined merging of materials — FSC™-certified wood and a tactile ceramic stoneware. This tactility is enhanced by the option of two different table top tiles; one plain and smooth, the other wavy and sculptural.





calm

wall lamp

Wrap Lounge Chair p. 99
Upphorsered in Ecriture 910 / Grey

Around Coffee Table p. 109
Compile Shelving System Config. 2 p. 119

Calm Wall Lamp Ø68 p. 132
Ply Rug p. 143



“With the details of its *curved backrest* that folds gently around the back legs and its warm materiality, the Cover Side Chair translates the ideas of Scandinavian *craftsmanship* into a modern design language.”

— Thomas Bentzen



Kink Vase p. 142
Compile Bookend p. 141

Compile Shelving System p. 119
Piton Portable Lamp p. 128

Set Table Lamp p. 126
Post Floor Lamp p. 134

Soft Side Table p. 108
Relevo Rug p. 143

Rest Sofa 3-Seater p. 97
Upholstered in Hearth 12





Fiber Armchair p. 80
Upholstered in Refined Leather Cognac



Enfold Sideboard p. 120
Piton Portable Lamp p. 128

“With the In Situ Modular Sofa, we wanted to combine the functions of *modularity* with the beauty of simple, *elegant lines* and a deep comfort.”

— Anderssen & Voll



Ply Rug p. 143

Soft Side Table p. 108
Around Coffee Table p. 109

In Situ Modular Sofa p. 96
Upholstered in Hallingdal 407

Kink Vase p. 142
Corky Glasses p. 142

Workshop Table p. 106
Rime Pendant Lamp Ø37 p. 122

Fiber Side Chair Tube Base p. 83
Upholstered in Balder 432



We were inspired by the shape of acorns for the *gentle lines* of the pendant while hinting towards the shaded expression of ice and rime for the glass of the design, allowing for the light to *shine slightly through* with a refined touch.”

— TAF Studio



mere bowl



“In essence, the Raise Carafe & Glass find their identity through their organic lines, encouraging the pieces to be *raised* when with friends, family and in everyday life.”

— Broberg & Ridderstråle





inside with —eve wilson, *Melbourne*



Eve Wilson is a Melbourne-based photographer who captures interiors, food, portraits, and places with an organic and intuitive curiosity, bringing a clean, crisp warmth to every shot. She lives in Cremorne, Melbourne, with her family, in a home which presents as a tiny traditional workers' cottage but is backed by a light-filled, modernist-inspired extension.



Midst Table Ø120
Cover Side Chair
Corky Carafe & Glasses

Points of view are essential to this house, which looks very different depending on how you come at it. From the street, it appears to be little more than a tiny, traditional workers cottage, just over four meters wide. But peek down the laneway and you'll see a mass of pink breeze blocks, vines entwined through them, flowers spilling out over glass, wood, and concrete. "It's quite spectacular," Eve concedes.

Inside, a palette of warm greens, and browns delineates its spaces, marking a passage from the old to the new. At the center, a glass-walled corridor connects the two, while a small green internal courtyard injects a sense of calm that

permeates the whole building. It's an easeful, elegant, and grounded home to the photographer, her husband Jon, and their two young daughters, Elliot, and June. Pleasingly for Eve, it offers up a new view almost every day.

Tell me about the home you've built

It's one of two tiny cottages, and we started living next door. We always eyed it, because it has a north-facing laneway, which is really good for Melbourne's northern light. When finally, we were lucky enough to get the opportunity to buy it, it hadn't been touched since the 1950s.

Can you walk me through it?

When you enter the house, you start in the oldest space. That's still quite traditionally built, so it's still got the cornices, the lighting roses, and it's all in a palette of warm off-whites. But as you move through it, you come to greens—these tastes of the new section. There are two bedrooms, a bathroom, and my study, which are all in the old building. Essentially the two buildings are joined together by a walkway. There's a large window to one side, and the tiniest little green courtyard which takes you down into the new space, all concrete, wood, greens, and the pink exterior. That's where you get all the texture and a completely different warmth.

How did you choose Studio Bright to design it?

The site is only 4.27 meters wide, so I spent a long time looking for an architect who would be excited to do something innovative with this footprint. We have two kids and a dog, so we needed enough space for everyone to fit. The house was so tiny that it required personality, creativity—not just an open plan with a white box on the back. Studio Bright had some interesting ideas right off the bat; the house they first designed for us is not too different from where we ended up.

Why was the courtyard so important?

Cremorne, the suburb we live in, is a big urban jungle: it's all warehouses and concrete, office spaces, tiny blocks. We wanted to make sure that we could always look out onto the green. It's like a little oasis out there—it's very calming.



Linear Steel Bench



Nerd Counter Stool
Ridge Vase

“One of the things I love the most is when we're all using different spaces ... Because of the courtyard, we can see through to where they are, and vice versa. There's this really nice connection; everyone's doing something different, but you still feel like you're all together.”

Where do you spend the most time as a family at home?

I made sure we had as big a kitchen table as we could. I wanted to be able to do a few things there at once—I'll read the paper with a coffee while the kids are drawing. There's music going, and if they're lucky someone's made pancakes. We spend a bit of time around that table. But actually, one of the things I love the most is when we're all using different spaces. The kids might be watching a movie or playing in the lounge room, while Jonny and I are sitting at the table, but because of the courtyard, we can see through to where they are, and vice versa. There's this really nice connection; everyone's doing something different, but you still feel like you're all together.

You also have a lot of artwork dotted throughout.

We've got quite a lot of little ceramics, vases, and little sculptures that I've collected throughout my career. When I was younger, I used to spend a lot of time photographing ceramicists and artists and bought a lot of pieces from people I came across. I also have some nice new things I picked up in Japan this year. It's an ever-evolving collection. •



Cover Lounge Chair
Kink Vase
Relevo Rug



Flow Trolley p. 120
Tip Floor Lamp p. 135



The Flow Trolley brings the concept of functional design into a modern context through its grooved trays in embossed metal for a *contemporary expression*.



Mere Bowl p. 142
Ridge Vase p. 142

Nerd Counter Stool p. 90
Raise Glasses p. 142

kink vase



Kink Vase p. 142

“My starting point for the Kink Vase was an exploration of how new forms could be created through the digital manipulation of simple shapes. The design combines this appreciation of modern technology with traditional ceramic craft, resulting in a piece that is both contemporary and sculptural.”

— Earnest Studio



Wave Tray p. 142
Kink Vase p. 142

Rime Pendant Lamp Ø95 p. 122
Ply Rug p. 143

Workshop Chair p. 86
Workshop Table p. 106

Fiber Side Chair Swivel Base p. 84
Upholstered In Clay 12

Raise Glasses p. 142
Mere Bowl p. 142

Top Pendant Lamp Ø36 p. 123
Silent Vase p. 142

Soft Table p. 107
Visu Chair-Wood Base p. 87



dots

coat hooks

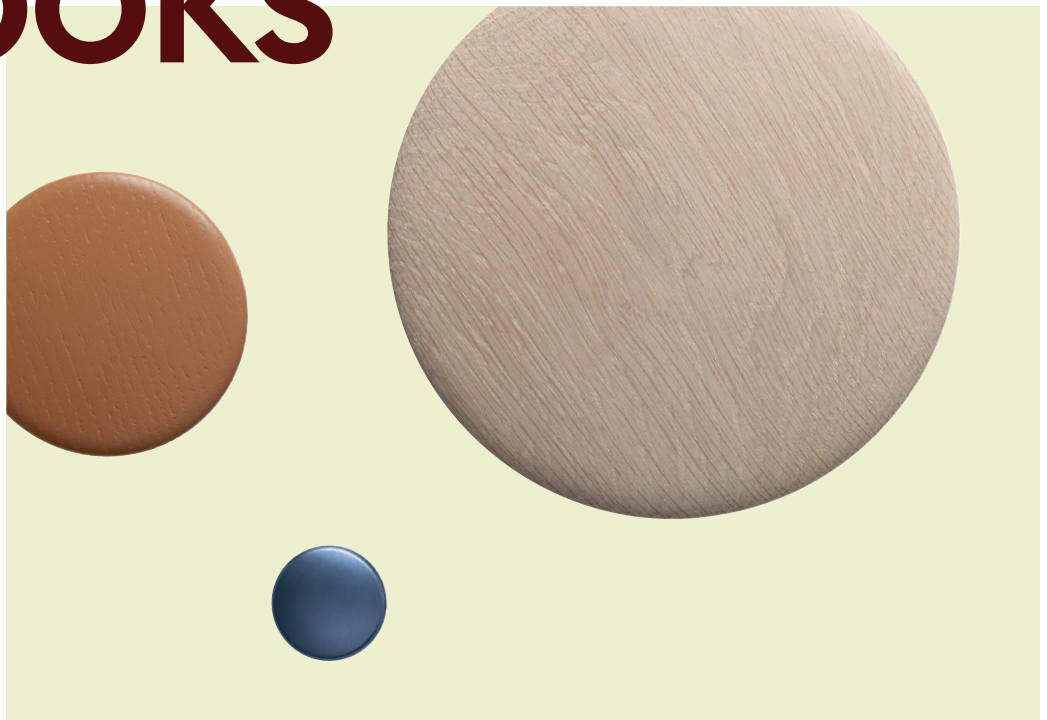



Story Pinboard p. 141

Tip Table Lamp p. 129
Sketch Toolbox p. 141





Around Coffee Table p. 109
Soft Side Table p. 108

Relevo Rug p. 143
Post Floor Lamp p. 134

Connect Soft Modular Sofa
Corner Config. p. 94
Upholstered in Ecriture 910

Acting as the heart of the home,
the Connect Soft *Modular* Sofa
brings together elegantly slender
proportions with a *deeply inviting*
and ultra-soft comfort.



“The Post Floor Lamp came from the idea of exploring the *flexibility of the magnetic joint*, giving the user the freedom to position and dim the lamp’s light units according to individual needs.”

— Earnest Studio

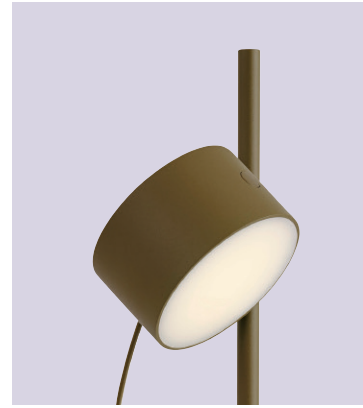



Mingle Cushion p. 143

Outline Daybed p. 93
Upholstered in Ecriture 910

“My idea was to create a series of cushions based on the simple intertwinement of color and textile. It turned out to be an exciting journey through the world of color and texture and in the end we found a combination where the two mingle well and complement each other.”

— Thomas Bentzen

Post Floor & Post Wall Lamp pp. p. 133-134
Compile Shelving System p. 119

Workshop Coffee Table p. 108
Pebble Rug p. 143

Situ Modular Sofa Corner Config. 2 p. 96
Upholstered in Vidar 554





Pull Floor Lamp p. 134
Piton Portable Lamp p. 128

Oslo Lounge Chair Swivel Base p. 100
Upholstered In Colline 737

Fiber Side Chair Swivel Base p. 84
Upholstered in Canvas 926, 984 & Remix 452

Linear Wood Table p. 105
Ridge Vase p. 142

Strand Pendant Lamp Ø80 p. 122





Ambit Wall Lamp p. 132

Soft Side Table p. 108
Ridge Vase p. 142

Outline Chair p. 93
Upholstered in Clay 12

Outline Sofa 3,5-Seater p. 93
Upholstered in Grace Leather Camel/
Polished Aluminium

Strand Table Lamp p. 129
Fine Suspension Lamp p. 125

Couple Coffee Table p. 108
Relevo Rug p. 143





We discovered a unique dynamic between linear and rounded shapes that gives the lamp its unique outline, making the Ambit Pendant Lamp a timeless design that you'll never grow tired of while its handspun aluminum material and contrasting white inner make for an elegant touch.”

— TAF Studio



Beam Table Lamp p. 197

Being a modernly functional design, the Beam Table Lamp emits *light from both ends* of an angled cylinder shape. The lamp can be altered for any position, whether it be as direct lighting or for an *ambient glow*.



Bringing a friendly expression to the traditional coat hook, the Dots Coat Hook is a functionally sculptural design to be arranged on the wall in any pattern and color combination desired.





Rime Pendant Lamp Ø18 p. 122
Workshop Chair p. 86

Framed Mirror p. 139
Folded Shelves p. 138



E27 Pendant Lamp p. 125

The E27 Pendant Lamp joins together the ideas of industrial design and Scandinavian *simplicity*. With its naked LED bulb and sleek in a playful *silicone rubber* material, the design makes for a simple yet distinctive addition to any home.



Piton Portable Lamp p. 128
Kink Vase p. 142

Arced Mirror p. 139
Mere Bowl p. 142

our sustainable perspectives

At Muuto, we aim to take responsibility for our operations and reflect on the choices we make and how our priorities affect the well-being of people and the environment. From the materials we select to the partners we work with, the independent institutes we test and certify our products through, and all the way down to our packaging. Our approach is based on knowledge and staying curious. With each new advancement in the field and as new research emerges, we keep searching for new perspectives on sustainability across all our operations. *Listening. Learning. And improving.*

It Starts With Enduring Designs

Long-lasting products—As a design-driven company, we want our designs to be appealing now—and in the future. Rooted in Scandinavian heritage, we craft timeless designs meant for passing down through generations.

Continuous testing is at the core of our development processes to keep the quality of our product high. For high levels of strength and stability, our products are certified by independent institutes that are well-respected authorities in the industry—following industry standards like the European Standard EN and the North American standard ANSI/BIFMA. Together, these industry standards assure that our designs are durable.

All of Muuto's BIFMA-tested designs are covered by a 5-year warranty alongside a 3-year warranty on all other products.

Reflecting On Materials

Conscious designs—Whenever we develop a new product or improve existing ones with our designers, we reflect on its impact on your health, your surroundings, and the environment.

We continuously seek new perspectives and work with the best in our industry to learn about new techniques and materials. The search for the right materials is an integral part of our design process, and we put great importance on all the materials that comprise a design and their life cycle.

As part of this journey, we launched the new generation of Fiber Chairs made with an innovative composite of FSC™-certified (FSC-CO28824) wood fibers and 100% recycled plastic, designed with a wish to improve our environmental impact.

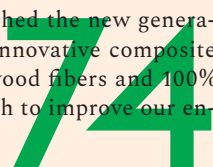



Fiber Side Chair Tube Base p. 83
Soft Side Table p. 108
Sketch Toolbox p. 141
Dots Wood Coat Hooks p. 137

The Air We Breathe Indoor

Healthier indoor climates—Even in indoor environments, where we spend so much of our time, the air quality is vital to our sense of well-being. In any space and often impossible to see, chemicals are emitted into the air. These emissions come from all kinds of objects in our everyday lives. The type of emissions that can have an adverse effect on our health contain Volatile Organic Compounds (VOCs). In fact, the majority of VOCs can be found at home—in certain types of soaps, perfume and cosmetics, cleaning products and disinfectants, fuel, paint, plastic and the like.

At Muuto, we want our furniture to enhance your surroundings, while at the same time, creating healthier indoor climates. That's why we go to great lengths to have our furniture tested to secure low emitting products. So far, the vast majority of our furniture collection is VOC tested.

Reasons To Feel Reassured

Certificates & Eco labels—There are numerous types of labels and certificates, and we have chosen the ones most relevant to you — and our portfolio of products. Several of our designs have the following certifications and labels:

The EU Ecolabel Certification: This renowned certification is well-respected worldwide as it identifies products having a reduced environmental impact spanning a product's total lifecycle — from raw material to disposal.

Declare Red List free label: A platform based on transparency that lets you see the origins and lifecycle of a product.

GreenTag Level C-certification: Recognized worldwide as a trusted, independent eco-label certification, the Global GreenTag was established to empower you, as a consumer, to confidently choose designs founded with sustainable initiatives

within a wide variety of parameters—from minimizing hazardous substances, wood from sustainable forestry and durability.

FSC™-certification (FSC-C028824): The Forest Stewardship Council™ (FSC) aims to ensure that forests are managed in an environmentally responsible manner that preserves the natural surroundings while supporting the local community. Look for our FSC® -certified products.

Our Work Internally

Our operation—We always consider how our decisions will affect the lives of those around us. That also includes evaluating our internal operations.

Our Danish HQ, offices and warehouses are running on 100% renewable energy through green certificates. A move that lowers our overall carbon footprint. It's an initiative we are in the process of incorporating in all our Muuto showrooms and stores around the world.

The Danish company Målbar offers a screening tool that lets us measure our CO₂e-emission per product. By tracking a product's components and their origins it's possible to calculate the total CO₂e-emission of a product. By using Målbar for tracking emissions we are able to learn and improve our operations by taking informed and well-considered choices about the products we bring to the market.

A Shared Responsibility

Our suppliers—As we aim to take responsibility for our operations, we expect and demand the same from our suppliers. In striving to ensure that our designs are safely produced by skilled workers who operate under safe and healthy conditions, we have all our manufacturers sign our Code of Conduct.

As a member of the United Nations Global Compact, our Code of Conduct is aligned with the UN Global Compact principles within human rights, labour, environment, and anti-corruption. For us, it's essential that our suppliers share the same mindset when it comes to socially responsible practices.

Our Path Forward

Our ambitions for the future reflect a humble yet committed approach to what lies ahead and how we get there. Learn more about our sustainability perspectives and explore the goals that continue to guide our work now and in the future at muuto.com/sustainability



The mark of responsible forestry

furniture

78

lighting

191

accessories

136

Create your very own Muuto designs with our digital tools, tailored to your individual taste and space.

Customize your design

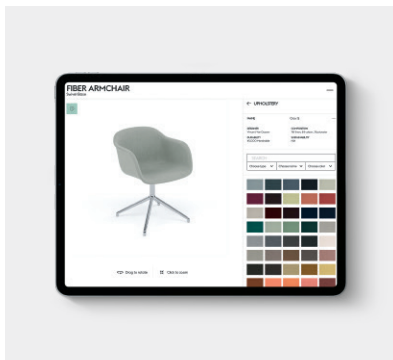

Configurator

Textile or Leather? Full or front upholstery? Green or Grey textile? Legs in Black or Chrome? Choosing among the nearly infinite Made-To-Order possibilities can seem overwhelming.

Discover our vast selection of configurable designs, marked with a Configurable label, and customize your favorite design in the Product Configurator, exploring more than 100.000 combinations of colors, textiles, and leather upholstery across our entire sofa range along with selected chairs and tables.



Make our designs truly yours on muuto.com/configurator.

Try our products in your own home

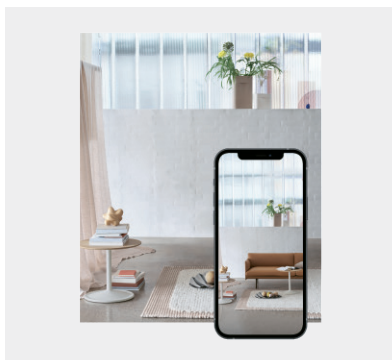

Augmented Reality

Ever wondered how a Muuto sofa would look in your home? With our Augmented Reality tool, you can place our sofas in your own home!

Simply use the configurator to customize your chosen piece by playing around with materials, trying different colors and perhaps changing the legs. Then proceed to the AR tool to see a movable 3D image of your design in your room.



Visit muuto.com/AR to explore.

Tailor your modular design

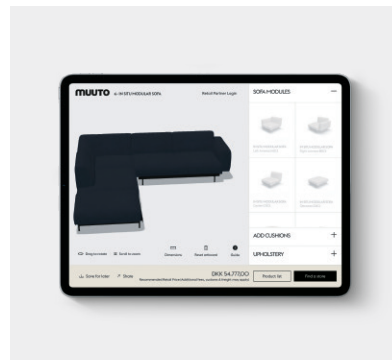

Planner

Our range of modular designs offers nearly endless possibilities, allowing you to customize our design to your exact aesthetic and spatial needs.



Visit planner.muuto.com and start planning.

An Extensive Ready-To-Ship Collection

With our extensive Ready-To-Ship collection, many of our designs are available for quick shipping in a broad selection of colors and upholsterys, spanning across furniture, lighting, and accessories. Explore all designs on the following pages and muuto.com.

Availability

Please note that all variants are subject to stock availability and certifications across regions. Please check availability with your local retailer.

Store Locator

Have you fallen in love with a design? Find your nearest Muuto dealers in our Store Locator on muuto.com/store-locator or visit muuto.com/online-shops for an overview of our online dealers.

Prices

For information on current prices in your local currency, please consult your Muuto dealer or check out the most recent and valid prices on our website muuto.com.

Chairs & Stools



Fiber Armchair
—Wood Base



Fiber Armchair
—Tube Base



Fiber Armchair
—Sled Base



Fiber Armchair
—Swivel Base



Fiber Armchair
—Swivel Base w. Castors



Fiber Armchair
—Swivel Base w. Gas Lift,
Castors & Tilt



Fiber Soft Armchair
—Wood Base



Fiber Soft Armchair
—Tube Base



Fiber Soft Armchair
—Swivel Base



Fiber Soft Armchair
—Swivel Base w. Castors



Fiber Soft Armchair
—Swivel Base w. Castors
& Tilt



Fiber Conference Armchair
—Wood Base



Fiber Conference Armchair
—Tube Base



Fiber Conference Armchair
—Swivel Base

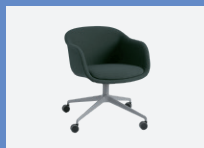

Fiber Conference Armchair
—Swivel Base w. Castors



Fiber Conference Armchair
—Swivel Base w. Gas Lift,
Castors & Tilt



Fiber Side Chair
—Wood Base



Fiber Side Chair
—Tube Base



Fiber Side Chair
—Sled Base



Fiber Side Chair
—Swivel Base



Fiber Side Chair
—Swivel Base w. Castors



Fiber Side Chair
—Swivel Base w. Castors
& Tilt



Cover Armchair



Cover Side Chair



Nerd Chair



Loft Chair



Workshop Chair



Workshop Bench



Visu Chair
—Wood Base



Visu Chair
—Tube Base



Visu Chair
—Sled Base



Oslo Side Chair



Fiber Bar Stool
—Wood Base w. backrest



Fiber Bar Stool
—Tube Base w. backrest



Fiber Counter Stool
—Wood Base w.o. backrest



Fiber Counter Stool
—Wood Base w.o. backrest

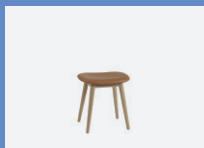

Fiber Stool
—Wood Base

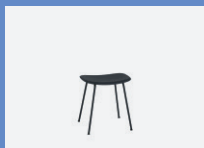

Fiber Stool
—Tube Base

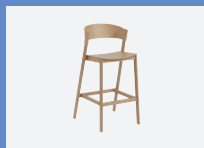

Cover Bar Stool



Nerd Bar Stool



Loft Bar Stool



Visu Bar Stool



Oslo Bar Stool

Fiber Armchair – Wood Base
by Iskos-Berlin



Material

Shell without upholstery: 100% recycled plastic reinforced with strength-improving additives and mixed with up to 25% FSC™-certified wood fibers. Shell with upholstery: 100% recycled plastic reinforced with strength-improving additives and mixed with up to 25% wood fibers. Shell can be fully or front upholstered with textile, imitation leather, or leather. Leather from selected premium leather suppliers. Due to the partly natural material of the shell, slight color variations can occur—base in FSC™-certified oak with water-based lacquer. For the Stained Dark Brown version, slight color variations can occur. The Fiber Series without upholstery is EU Ecolabel Certified.

Ready-To-Ship Options

(Shell / Base) Black / Anthracite Black	
Grey / Grey	
Dusty Green / Dusty Green	
Ochre / Oak	
Natural White / Oak	
Black / Stained Dark Brown	

(Leather Upholstery / Base) Refine Leather Cognac / Oak	
--	--

Explore all Made-To-Order options on muuto.com/products.



The mark of responsible forestry
FSC® C028824

Made with recycled materials

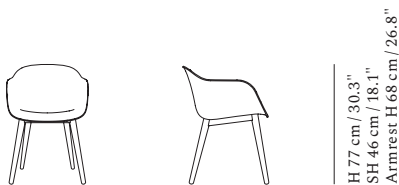

W 54,5 cm / 21.5" D 56 cm / 22"

Fiber Armchair – Tube Base
by Iskos-Berlin



Material

Shell without upholstery: 100% recycled plastic reinforced with strength-improving additives and mixed with up to 25% FSC™-certified wood fibers. Shell with upholstery: 100% recycled plastic reinforced with strength-improving additives and mixed with up to 25% wood fibers. Shell can be fully or front upholstered with textile, imitation leather, or leather. Leather from selected premium leather suppliers. Due to the partly natural material of the shell, slight color variations can occur. Base in powder-coated steel. The Fiber Series without upholstery is EU Ecolabel Certified.

Ready-To-Ship Options

(Shell / Base) Black / Anthracite Black	
Grey / Grey	
Dusty Green / Dusty Green	
Natural White / White	
Ochre / Anthracite black	

(Leather Upholstery / Base) Refine Leather Cognac / Anthracite Black	
---	--

Explore all Made-To-Order options on muuto.com/products.



The mark of responsible forestry
FSC® C028824

Made with recycled materials



W 54,5 cm / 21.5" D 56 cm / 22"

Fiber Armchair – Sled Base
by Iskos-Berlin



Material

Shell without upholstery: 100% recycled plastic reinforced with strength-improving additives and mixed with up to 25% FSC™-certified wood fibers. Shell with upholstery: 100% recycled plastic reinforced with strength-improving additives and mixed with up to 25% wood fibers. Shell can be fully or front upholstered with textile, imitation leather, or leather. Leather from selected premium leather suppliers. Due to the partly natural material of the shell, slight color variations can occur. Base in powder-coated steel. The Fiber Series without upholstery is EU Ecolabel Certified.

Additional Information

This product is Made-To-Order. Explore all Made-To-Order options on muuto.com/products.



The mark of responsible forestry
FSC® C028824

Made with recycled materials

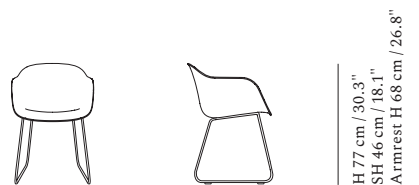

W 54,5 cm / 21.5" D 55 cm / 21.7"

Fiber Armchair – Swivel Base by Iskos-Berlin



Material

Shell without upholstery: 100% recycled plastic reinforced with strength-improving additives and mixed with up to 25% FSC™-certified wood fibers. Shell with upholstery: 100% recycled plastic reinforced with strength-improving additives and mixed with up to 25% wood fibers. Shell can be fully or front upholstered with textile, imitation leather, or leather. Leather from selected premium leather suppliers. Due to the partly natural material of the shell, slight color variations can occur. Base in die casted aluminum. The Fiber Series without upholstery is EU Eco-label Certified.

Ready-To-Ship Options (Leather Upholstery / Base)

Refine Leather Cognac / Anthracite Black



Explore all Made-To-Order options on muuto.com/products.



The mark of responsible forestry
FSC™ C028824

Made with recycled materials

Fiber Armchair – Swivel Base w. Castors – Swivel Base w. Gas Lift & Castors by Iskos-Berlin



Material

Shell without upholstery: 100% recycled plastic reinforced with strength-improving additives and mixed with up to 25% FSC™-certified wood fibers. Shell with upholstery: 100% recycled plastic reinforced with strength-improving additives and mixed with up to 25% wood fibers. Shell can be fully or front upholstered with textile, imitation leather, or leather. Leather from selected premium leather suppliers. Due to the partly natural material of the shell, slight color variations can occur. Base in die casted aluminum with castors. Black, Grey, Dusty Green and Polished Aluminum base with black castors. White base with white castors. The Fiber Series without upholstery is EU Eco-label Certified.

Additional Information

This product is Made-To-Order.

Explore all Made-To-Order options on muuto.com/products.



The mark of responsible forestry
FSC™ C028824

Made with recycled materials

Fiber Soft Armchair – Wood Base by Iskos-Berlin



Material

Shell from 100% recycled plastic mixed with strength-improving additives. The recycled plastic comes from post-consumer waste. Seat, back and armrest is clad with multiple layers of foam and wadding and finished with textile, imitation leather or leather upholstery. Leather from selected premium leather suppliers. Wood base in FSC™-certified oak with water-based lacquer. Plastic glides. For Stained Dark Brown version slight color variations can occur.

Ready-To-Ship Options (Textile Upholstery / Base)

Ecriture 240 / Oak



Explore all Made-To-Order options on muuto.com/products.



The mark of responsible forestry
FSC™ C028824

Made with recycled materials



W 54,5 cm / 21.5"



D 56 cm / 22"

H 77 cm / 30.3"
SH 46 cm / 18.1"
Armrest H 68 cm / 26.8"



W 54,5 cm / 21.5"



D 56 cm / 22"

H 77 cm / 30.3"
SH 46 cm / 18.1"
Armrest H 68 cm / 26.8"



W 70 cm / 27.6"



D W 70 cm / 27.6"

H 72-84 cm / 28.3-33.1"
SH 42-54 cm / 16.5-22.3"
Armrest H 63-75 cm / 24.8-29.5"



W 63,5 cm / 25"



D 61 cm / 24"

H 77,5 cm / 30,5"
SH 49 cm / 19,3"
Armrest Height: 67,2 cm / 26,5"

Fiber Soft Armchair
- Tube Base
by Iskos-Berlin



Material
Shell from 100% recycled plastic mixed with strength-improving additives. The recycled plastic comes from post-consumer waste. The seat, back, and armrest are clad with multiple layers of foam and wadding and finished with textile, imitation leather, or leather upholstery. Leather from selected premium leather suppliers. Tube base in powder-coated steel. Plastic glides.

Ready-To-Ship Options
(Textile Upholstery / Base)
Ecriture 240 / Grey



Explore all Made-To-Order options on muuto.com/products.

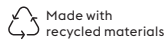

Fiber Soft Armchair
- Swivel Base
- Swivel Base w. Return
- Swivel Base w. Return & Tilt
by Iskos-Berlin



Material
Shell from 100% recycled plastic mixed with strength-improving additives. The recycled plastic comes from post-consumer waste. The seat, back, and armrest are clad with multiple layers of foam and wadding and finished with textile, imitation leather, or leather upholstery. Leather from selected premium leather suppliers. Swivel base in powder-coated aluminum. Plastic glides.

Ready-To-Ship Options
(Textile Upholstery / Base)
Ecriture 240 / Grey



Explore all Made-To-Order options on muuto.com/products.

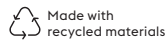

Fiber Soft Armchair
- Swivel Base w. Castors
- Swivel Base w. Castors & Tilt
- Swivel Base w. Gas Lift, Castors & Tilt
by Iskos-Berlin



Material
Shell from 100% recycled plastic mixed with strength-improving additives. The recycled plastic comes from post-consumer waste. The seat, back, and armrest are clad with multiple layers of foam and wadding and finished with textile, imitation leather, or leather upholstery. Leather from selected premium leather suppliers. Swivel base in powder-coated aluminum. Black castors.

Additional Information
This product is Made-To-Order.
Explore all Made-To-Order options on muuto.com/products.

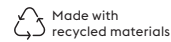

W 63,5 cm / 25" D 60,5 cm / 23.8"

H 77,5 cm / 30.5"
SH 49 cm / 19.3"
Armrest Height:
67,2 cm / 26.5"



W 63,5 cm / 25" D 60,5 cm / 23.8"

H 77,5 cm / 30.5"
SH 49 cm / 19.3"
Armrest Height:
67,2 cm / 26.5"



W 63,5 cm / 25" D 60,5 cm / 23.8"

H 77,5 cm / 30.5"
SH 49 cm / 19.3"
Armrest Height:
67,2 cm / 26.5"



W 63,5 cm / 25" D 60,5 cm / 23.8"

H 77,5 cm / 30.5"
SH 49 cm / 19.3"
Armrest Height:
67,2 cm / 26.5"



W 63,5 cm / 25" D 61 cm / 24"

H 77,5 cm / 30.5"
SH 49 cm / 19.3"
Armrest Height:
67,2 cm / 26.5"



W 63,5 cm / 25" D 60,5 cm / 23.8"

H 77,5 cm / 30.5"
SH 49 cm / 19.3"
Armrest Height:
67,2 cm / 26.5"



W 63,5 cm / 25" D 68 cm / 26.8"

H 73-85 cm / 28.9"-33.5"
SH 45-57 cm / 17.6"-22.3"
Armrest Height:
63-75 cm / 24.8"-29.5"

Fiber Conference Armchair
– Wood Base
by Iskos-Berlin



Material

Shell made in 100% recycled plastic and strength-improving virgin plastic additives. The recycled plastic comes from post-consumer waste. Fully upholstered in textile, imitation leather or leather. Cushion in molded foam, fixed and non-removable. Wood base in FSC™-certified oak or beech with water-based lacquer. For Stained Dark Brown version slight color variations can occur.

Ready-To-Ship Options
(Textile Upholstery / Base)

Remix 133 / Grey



Explore all Made-To-Order options on muuto.com/products.



The mark of
responsible forestry
FSC® C028824

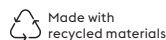

Fiber Conference Armchair
– Tube Base
by Iskos-Berlin



Material

Shell made in 100% recycled plastic and strength-improving virgin plastic additives. The recycled plastic comes from post-consumer waste. Fully upholstered in textile, imitation leather or leather. Cushion in molded foam, fixed and non-removable. Base in powder-coated steel.

Additional Information

This product is Made-To-Order.
Explore all Made-To-Order options on muuto.com/products.

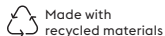

Fiber Conference Armchair
– Swivel Base
by Iskos-Berlin



Material

Shell made in 100% recycled plastic and strength-improving virgin plastic additives. The recycled plastic comes from post-consumer waste. Fully upholstered in textile, imitation leather or leather. Cushion in molded foam, fixed and non-removable. Base in die-casted aluminum. Plastic glides.

Ready-To-Ship Options (Swivel Base w.o. Return)
(Textile Upholstery / Base)

Remix 133 / Grey



Explore all Made-To-Order options on muuto.com/products.

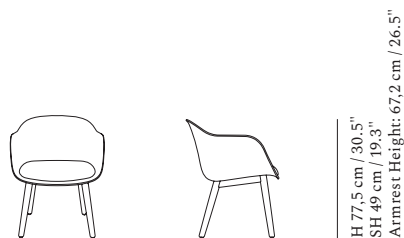
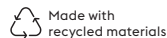

W 63,5 cm / 25"

D 61 cm / 24"

H 77,5 cm / 30,5"
SH 49 cm / 19,3"
Armrest Height: 67,2 cm / 26,5"

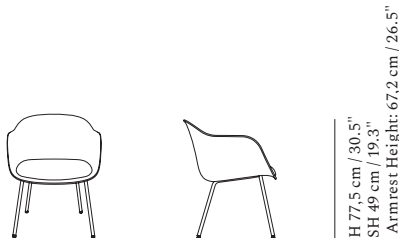

W 63,5 cm / 25"

D 61 cm / 24"

H 77,5 cm / 30,5"
SH 49 cm / 19,3"
Armrest Height: 67,2 cm / 26,5"

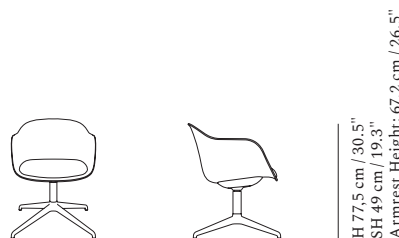

W 63,5 cm / 25"

D 60,5 cm / 23,8"

H 77,5 cm / 30,5"
SH 49 cm / 19,3"
Armrest Height: 67,2 cm / 26,5"

Fiber Conference Armchair
 – Swivel Base w. Castors
 – Swivel Base w. Gas Lift, Castors & Tilt
 by Iskos-Berlin



Material
 Shell made in 100% recycled plastic and strength-improving virgin plastic additives. The recycled plastic comes from post-consumer waste. Fully upholstered in textile, imitation leather or leather. Cushion in molded foam, fixed and non-removable. Base in die-casted aluminum. Black castors. Pressurized gas lift cylinder.

Additional Information
 This product is Made-To-Order.
 Explore all Made-To-Order options on muuto.com/products.

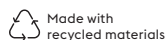

Fiber Side Chair – Wood Base
 by Iskos-Berlin



Material
 Shell without upholstery: 100% recycled plastic reinforced with strength-improving additives and mixed with up to 25% FSC™-certified wood fibers. Shell with upholstery: 100% recycled plastic reinforced with strength-improving additives and mixed with up to 25% wood fibers. Shell can be fully upholstered with textile, imitation leather, or leather. Leather from selected premium leather suppliers. Due to the partly natural material of the shell, slight color variations can occur. Base in FSC™-certified oak with water-based lacquer. For Stained Dark Brown version slight color variations can occur. The Fiber Series without upholstery is EU Ecolabel Certified.

Ready-To-Ship Options
 (Shell / Base)

Black / Anthracite Black	
Grey / Grey	
Dusty Green / Dusty Green	
Ochre / Oak	
Natural White / Oak	

(Leather Upholstery / Base)
 Refine Leather Cognac / Oak

Explore all Made-To-Order options on muuto.com/products.



The mark of responsible forestry
 FSC® C028824

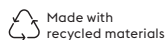

Fiber Side Chair – Tube Base
 by Iskos-Berlin



Material
 Shell without upholstery: 100% recycled plastic reinforced with strength-improving additives and mixed with up to 25% FSC™-certified wood fibers. Shell with upholstery: 100% recycled plastic reinforced with strength-improving additives and mixed with up to 25% wood fibers. Shell can be fully upholstered with textile, imitation leather, or leather. Leather from selected premium leather suppliers. Due to the partly natural material of the shell, slight color variations can occur. Base in powder-coated steel. The Fiber Series without upholstery is EU Ecolabel Certified.

Ready-To-Ship Options
 (Shell / Base)

Black / Anthracite Black	
Grey / Grey	
Dusty Green / Dusty Green	
Natural White / White	
Ochre / Anthracite Black	

(Leather Upholstery / Base)
 Refine Leather Cognac / Anthracite Black

Explore all Made-To-Order options on muuto.com/products.



The mark of responsible forestry
 FSC® C028824

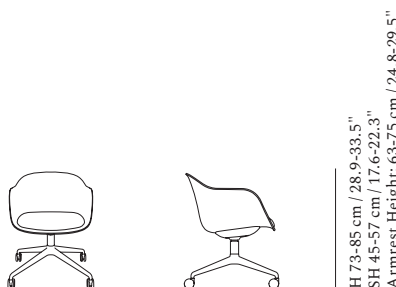
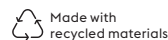

W 63,5 cm / 25"

D 60,5 cm / 23.8"



W 63,5 cm / 25"

D 68 cm / 26.8"



W 49,5 cm / 19.5"

D 53 cm / 20.9"



W 51 cm / 20.1"

D 53 cm / 20.9"

Fiber Side Chair – Sled Base
by Iskos-Berlin



Material
Shell without upholstery: 100% recycled plastic reinforced with strength-improving additives and mixed with up to 25% FSC™-certified wood fibers. Shell with upholstery: 100% recycled plastic reinforced with strength-improving additives and mixed with up to 25% wood fibers. Shell can be fully upholstered with textile, imitation leather, or leather. Leather from selected premium leather suppliers. Due to the partly natural material of the shell, slight color variations can occur. Base in powder-coated steel. The Fiber Series without upholstery is EU Ecolabel Certified.

Additional Information
This product is Made-To-Order.
Explore all Made-To-Order options on muuto.com/products.



Made with recycled materials

Fiber Side Chair – Swivel Base
by Iskos-Berlin



Material
Shell without upholstery: 100% recycled plastic reinforced with strength-improving additives and mixed with up to 25% FSC™-certified wood fibers. Shell with upholstery: 100% recycled plastic reinforced with strength-improving additives and mixed with up to 25% wood fibers. Shell can be fully upholstered with textile, imitation leather, or leather. Leather from selected premium leather suppliers. Due to the partly natural material of the shell, slight color variations can occur. Base in die-casted aluminum. The Fiber Series without upholstery is EU Ecolabel Certified.

Ready-To-Ship Options
(Leather Upholstery / Base)
Refine Leather Cognac / Anthracite Black

Explore all Made-To-Order options on muuto.com/products.



Made with recycled materials

Fiber Side Chair
– Swivel Base w. Castors
– Swivel Base w. Gas Lift & Castors
by Iskos-Berlin



Material
Shell without upholstery: 100% recycled plastic reinforced with strength-improving additives and mixed with up to 25% FSC™-certified wood fibers. Shell with upholstery: 100% recycled plastic reinforced with strength-improving additives and mixed with up to 25% wood fibers. Shell can be fully upholstered with textile, imitation leather, or leather. Leather from selected premium leather suppliers. Due to the partly natural material of the shell, slight color variations can occur. Base in die-casted aluminum with castors. Black, Grey, Dusty Green, and Polished Aluminum base with black castors. The Fiber Series without upholstery is EU Ecolabel Certified.

Additional Information
This product is Made-To-Order.
Explore all Made-To-Order options on muuto.com/products.



Made with recycled materials



W 47,5 cm / 18.7" D 51,5 cm / 20.3"

H 77 cm / 30.3"
SH 46 cm / 18.1"



W 47,5 cm / 18.7" D 53 cm / 20.9"

H 77 cm / 30.3"
SH 46 cm / 18.1"



W 47,5 cm / 18.7" D 53 cm / 20.9"

H 77 cm / 30.3"
SH 46 cm / 18.1"

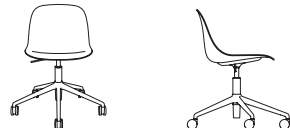

W 70 cm / 27.6" D 70 cm / 27.6"

H 72-84cm / 28.3-33.1"
SH 42-54cm / 16.5-22.3"

Cover Armchair
by Thomas Bentzen



Material
Oak and Stained Dark Brown versions: Back, seat and armrest in oak veneer, solid oak frame and legs. Colored versions: Back, seat and armrest in ash veneer, frame and legs are made from solid beech wood. All chairs with water-based lacquer. Upholstered seat with textile or leather. For Oak and Stained Dark Brown version slight color variations can occur. The Cover Series without upholstery is EU Ecolabel Certified.

Ready-To-Ship Options
Oak

- Stained Dark Brown
- Black
- Green
- Dark Beige

- (Leather Upholstery / Base)
Refine Leather Cognac / Oak
- Refine Leather Black / Black

Explore all Made-To-Order options on muuto.com/products.



Cover Side Chair
by Thomas Bentzen



Material
Back and seat in oak veneer, solid oak frame and legs with water-based lacquer. Stacking Pad in felt made from 60% post-consumer recycled content. Stackable up to 4 pcs. Upholstered seat with textile or leather. For Oak and Stained Dark Brown version slight color variations can occur. The Cover Series without upholstery is EU Ecolabel Certified.

Ready-To-Ship Options
Oak

- Stained Dark Brown
- Black
- Green
- Dark Beige

- (Leather Upholstery / Base)
Refine Leather Cognac / Oak
- Refine Leather Black / Black

Explore all Made-To-Order options on muuto.com/products.



Nerd Chair
by David Geckeler



Material
Oak and Stained Dark Brown version: Seat and back in form-pressed oak veneer. Legs in solid oak. Colored version: Seat and back in form pressed ash veneer. Legs in solid ash. All chairs with water-based lacquer. For Oak and Stained Dark Brown version slight color variations can occur.

Ready-To-Ship Options
(Shell / Base)

- Oak
- Stained Dark Brown
- Black
- Grey
- Midnight Blue
- Green
- Tan Rose

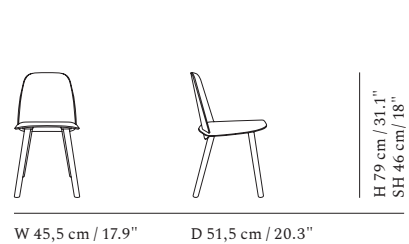
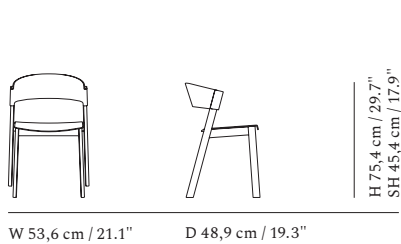
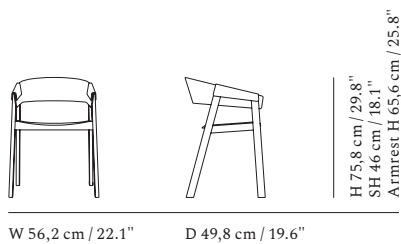

Loft Chair by Thomas Bentzen



Material

Seat and back are constructed with beech veneer layers and outer oak surface veneers with water-based lacquer. Upholstered seats with textile, imitation leather, or leather. Leather from selected premium leather suppliers. Frame in powder-coated steel. Plastic glides. For the Oak and Stained Dark Brown version, slight color variations can occur.

Ready-To-Ship Options

(Shell / Base)

Black / Black



Oak / Black



Oak / Dusty Green



Oak / Deep Red



Oak / Grey



Stained Dark Brown / Black



Explore all Made-To-Order options on muuto.com/products.

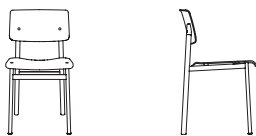

W 42,4 cm / 16.7"

D 48,8 cm / 19.2"

H 78,7 cm / 31.1"
SH 46 cm / 18"

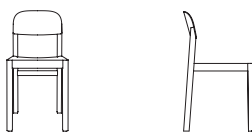

W 39,8 cm / 15.7"

D 46,3 cm / 18.2"

H 79,2 cm / 31.2"
SH 45 cm / 17.7"

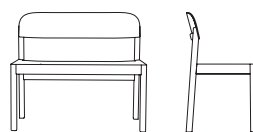

W 90,8 cm / 35.7"

D 46,3 cm / 18.2"

H 79,6 cm / 31.3"
SH 45,2 cm / 17.8"

Workshop Chair by Cecilie Manz



Material

Seat and back in oak veneer, frame and legs in solid oak. All parts with a water-based lacquer. For the Oak version, slight color variations can occur.

Ready-To-Ship Options

Oak



Black



Workshop Bench by Cecilie Manz



Material

The Workshop Bench is made using traditional techniques that emphasize craft and detailing. Frame and legs in solid oak, seat and back in form-pressed oak veneer—all parts in FSC™-certified wood coated with a water-based lacquer. Plastic glides. Oak version: slight color variations may occur due to the material's inherent characteristics.

Ready-To-Ship Options

Oak



Black



The mark of
responsible forestry
FSC™ C028824

Visu Chair – Wood Base
by Mika Tolvanen



Material

Oak version: Form-pressed oak veneer shell and base. Colored versions: Form-pressed ash veneer shell and base. All chairs with water-based lacquer. Fully upholstered shell with textile or leather. For the Oak version, slight color variations can occur.

Ready-To-Ship Options
(Shell / Base)

Oak / Oak	
White / Oak	
Black / Black	
Grey / Grey	
Midnight Blue / Midnight Blue	
Dark Green / Dark Green	
Dusty Green / Dusty Green	
Sand / Sand	
Tan Rose / Tan Rose	

Explore all Made-To-Order options on muuto.com/products.



W 46 cm / 18"

D 50 cm / 19.7"

H 78,5 cm / 31"
SH 46 cm / 18"

Visu Chair – Tube Base
by Mika Tolvanen



Material

Oak version: Seat and back in form pressed oak veneer. Colored version: Seat and back in form-pressed ash veneer. All chairs with water-based lacquer. Fully upholstered shell with textile or leather. Base in powder-coated steel. For the Oak version, slight color variations can occur.

Ready-To-Ship Options
(Shell / Base)

Black / Black

Explore all Made-To-Order options on muuto.com/products.



W 55 cm / 21.7"

D 52,5cm / 20.7"

H 81 cm / 31.9"
SH 47 cm / 18.5"

Visu Chair – Sled Base
by Mika Tolvanen



Material

Form-pressed ash veneer shell with water-based lacquer. Fully upholstered shell with textile or leather. Base in powder-coated steel. For the Oak version, slight color variations can occur.

Ready-To-Ship Options
(Shell / Base)

Black / Black

Explore all Made-To-Order options on muuto.com/products.



W 53 cm / 20.9"

D 50 cm / 19.7"

H 78,5 cm / 30.9"
SH 45 cm / 17.7"

Oslo Side Chair
by Anderssen & Voll



Configurable

Material

Steel frame, molded foam and textile upholstery. Base in chrome or powder-coated steel.

Explore all Made-To-Order options on muuto.com/products.

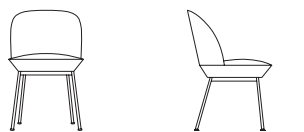

W 51 cm / 20.08" D 56 cm / 22.05"

H 80.5 cm / 31.7"
SH 45 cm / 17.72"

Fiber Counter & Bar Stool w. Back
– Wood Base
by Iskos-Berlin



Configurable

Material

Shell without upholstery: 100% recycled plastic reinforced with strength-improving additives and mixed with up to 25% FSC™-certified wood fibers. Shell with upholstery: 100% recycled plastic reinforced with strength-improving additives and mixed with up to 25% wood fibers. Shell can be fully upholstered with textile, imitation leather, or leather. Leather from selected premium suppliers. Due to the partly natural material of the shell, slight color variations can occur. Base in FSC™-certified oak with water-based lacquer. For Stained Dark Brown version slight color variations can occur. The Fiber Series without upholstery is EU Ecolabel Certified.

Ready-To-Ship Options

(Shell / Base)

Black / Anthracite Black



Grey / Grey



Natural White / Oak



(Leather Upholstery / Base)

Refine Leather Cognac / Oak



Explore all Made-To-Order options on muuto.com/products.



The mark of responsible forestry
FSC® C028824

Made with recycled materials

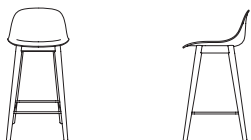

W 42,5 cm / 16.7" D 44,5 cm / 17.5"

H 87,5 cm / 34.4"
SH 65 cm / 25.6"

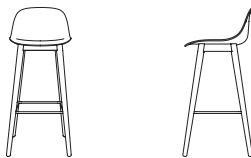

W 44,5 cm / 17.5" D 45,5 cm / 17.9"

H 97,5 cm / 38.4"
SH 75 cm / 29.5"

Fiber Counter & Bar Stool w. Back
– Tube Base
by Iskos-Berlin



Configurable

Material

Shell without upholstery: 100% recycled plastic reinforced with strength-improving additives and mixed with up to 25% FSC™-certified wood fibers. Shell with upholstery: 100% recycled plastic reinforced with strength-improving additives and mixed with up to 25% wood fibers. Shell can be fully upholstered with textile, imitation leather, or leather. Leather from selected premium suppliers. Due to the partly natural material of the shell, slight color variations can occur. Base in powder-coated steel. The Fiber Series without upholstery is EU Ecolabel Certified.

Ready-To-Ship Options

(Shell / Base)

Black / Anthracite Black



Grey / Grey



Natural White / White



(Leather Upholstery / Base)

Refine Leather Cognac / Anthracite Black



Explore all Made-To-Order options on muuto.com/products.



The mark of responsible forestry
FSC® C028824

Made with recycled materials



W 42,5 cm / 16.7" D 44,5 cm / 17.5"

H 87,5 cm / 34.4"
SH 65 cm / 25.6"

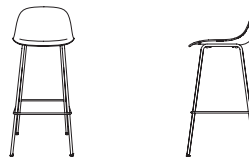

W 44,5 cm / 17.5" D 46,6 cm / 18.3"

H 97,5 cm / 38.4"
SH 75 cm / 29.5"

Fiber Counter & Bar Stool
– Wood Base
by Iskos-Berlin



Material

Shell without upholstery: 100% recycled plastic reinforced with strength-improving additives and mixed with up to 25% FSC™-certified wood fibers. Shell with upholstery: 100% recycled plastic reinforced with strength-improving additives and mixed with up to 25% wood fibers. Shell can be fully upholstered with textile, imitation leather, or leather. Leather from selected premium leather suppliers. Due to the partly natural material of the shell, slight color variations can occur. Base in FSC™-certified oak with water-based lacquer. For Stained Dark Brown version slight color variations can occur. The Fiber Series without upholstery is EU Ecolabel Certified.

Ready-To-Ship Options

(Shell / Base)

Black / Anthracite Black



Grey / Grey



Natural White / Oak



(Leather Upholstery / Base)

Refine Leather Cognac / Oak



Explore all Made-To-Order options on muuto.com/products.



The mark of responsible forestry
FSC® C028824

Made with recycled materials



H 66 cm / 26"
SH 65 cm / 25.6"

W 45 cm / 17.7"

D 42,5 cm / 16.7"

Fiber Counter & Bar Stool
– Tube Base
by Iskos-Berlin



Material

Shell without upholstery: 100% recycled plastic reinforced with strength-improving additives and mixed with up to 25% FSC™-certified wood fibers. Shell with upholstery: 100% recycled plastic reinforced with strength-improving additives and mixed with up to 25% wood fibers. Shell can be fully upholstered with textile, imitation leather, or leather. Leather from selected premium leather suppliers. Due to the partly natural material of the shell, slight color variations can occur. Base in powder-coated steel. The Fiber Series without upholstery is EU Ecolabel Certified.

Ready-To-Ship Options

(Shell / Base)

Black / Anthracite Black



Grey / Grey



Natural White / White



(Leather Upholstery / Base)

Refine Leather Cognac / Anthracite Black



Explore all Made-To-Order options on muuto.com/products.



The mark of responsible forestry
FSC® C028824

Made with recycled materials



H 66 cm / 26"
SH 65 cm / 25.6"

W 45 cm / 17.7"

D 44 cm / 17.3"

Fiber Stool – Wood Base
by Iskos-Berlin



Material

Shell without upholstery: 100% recycled plastic reinforced with strength-improving additives and mixed with up to 25% FSC™-certified wood fibers. Shell with upholstery: 100% recycled plastic reinforced with strength-improving additives and mixed with up to 25% wood fibers. Shell can be fully upholstered with textile, imitation leather, or leather. Leather from selected premium leather suppliers. Due to the partly natural material of the shell, slight color variations can occur. Base in FSC™-certified oak with water-based lacquer. For Stained Dark Brown version slight color variations can occur. The Fiber Series without upholstery is EU Ecolabel Certified.

Additional Information

This product is Made-To-Order.

Explore all Made-To-Order options on muuto.com/products.



The mark of responsible forestry
FSC® C028824

Made with recycled materials



H 46 cm / 18.1"
SH 45 cm / 17.7"

W 45 cm / 17.7"

D 35,5 cm / 14"



H 76 cm / 29.9"
SH 75 cm / 29.5"

W 45 cm / 17.7"

D 45,5 cm / 17.9"



H 76 cm / 29.9"
SH 75 cm / 29.5"

W 45 cm / 17.7"

D 46,5 cm / 18.3"

Fiber Stool – Tube Base
by Iskos-Berlin



Material
Shell without upholstery: 100% recycled plastic reinforced with strength-improving additives and mixed with up to 25% FSC™-certified wood fibers. Shell with upholstery: 100% recycled plastic reinforced with strength-improving additives and mixed with up to 25% wood fibers. Shell can be fully upholstered with textile, imitation leather, or leather. Leather from selected premium leather suppliers. Due to the partly natural material of the shell, slight color variations can occur. Base in powder-coated steel. The Fiber Series without upholstery is EU Ecolabel Certified.

Additional Information
This product is Made-To-Order. Explore all Made-To-Order options on muuto.com/products.



Made with recycled materials

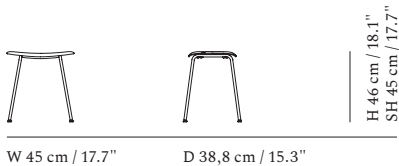

Cover Counter & Bar Stool
by Thomas Bentzen



Material
Back and seat in oak veneer, solid oak frame and legs. Made using FSC™-certified wood with water-based lacquer. Footrest protector in tumbled stainless steel. Upholstered seat with textiles or leather. For Oak and Stained Dark Brown version slight color variations can occur. The Cover Series without upholstery is EU Ecolabel Certified.

- Ready-To-Ship Options**
(Shell / Base)
- Oak ●
 - Stained Dark Brown ●
 - Black ●
 - Green ●
 - Dark Beige ●
- (Leather Upholstery / Base)
- Refine Leather Cognac / Oak ● ●
 - Refine Leather Black / Black ● ●

Explore all Made-To-Order options on muuto.com/products.

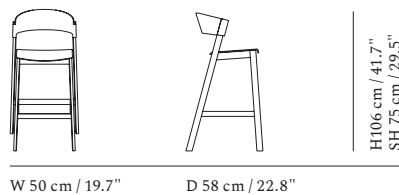
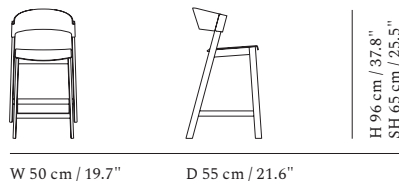

Nerd Counter & Bar Stool
by David Geckeler



Material
Oak and Stained Dark Brown version: Seat and back in form pressed oak veneer with solid oak legs. Colored version: Seat and back in form pressed ash veneer with solid ash legs. All stools with water-based lacquer. For Oak and Stained Dark Brown version slight color variations can occur.

- Ready-To-Ship Options**
(Shell / Base)
- Oak ●
 - Stained Dark Brown ●
 - Black ●
 - Grey ●
 - Midnight Blue ●
 - Green ●
 - Tan Rose ●

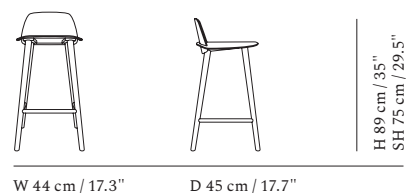
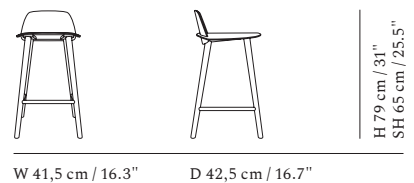

Loft Counter & Bar Stool
by Thomas Bentzen



Material
Back and seat in veneer with a beech core and an oak veneer top, both with a water-based lacquer. Textile or leather upholstered seat. Frame in powder-coated steel. For Oak and Stained Dark Brown version slight color variations can occur.

Ready-To-Ship Options
(Shell / Base)

- Black / Black ● ●

- Oak / Black ● ●

- Oak / Dusty Green ● ●

- Oak / Deep Red ● ●

- Oak / Grey ● ●

- Stained Dark Brown / Black ● ●

Explore all Made-To-Order options on muuto.com/products.

Visu Counter & Bar Stool
by Mika Tolvanen



Material
Oak and Stained Dark Brown version: Form pressed oak veneer shell and base. Colored version: Form pressed ash veneer shell and base. All stools with water-based lacquer. Fully upholstered shell with textile or leather. For Oak and Stained Dark Brown version slight color variations can occur.

Ready-To-Ship Options
(Shell / Base)

- Oak / Oak ● ●

- White / Oak ● ●

- Black / Black ● ●

- Grey / Grey ● ●

- Dark Green / Dark Green ● ●

- Tan Rose / Tan Rose ● ●

Explore all Made-To-Order options on muuto.com/products.

Oslo Counter & Bar Stool
by Anderssen & Voll



Material
Steel frame, moulded foam and textile upholstery. Base in chrome or powder-coated steel.

Explore all Made-To-Order options on muuto.com/products.



W 42,4 cm / 16.7" D 49 cm / 19.25"



W 41,3 cm / 16.3" D 40,1 cm / 15.8"



W 51 cm / 20.1" D 55 cm / 21.7"

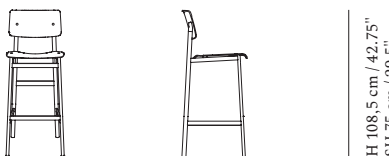

W 43,5 cm / 17.1" D 49 cm / 19.25"



W 42,4 cm / 16.7" D 41,8 cm / 16.5"

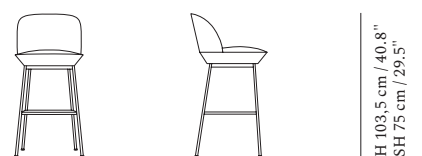

W 51 cm / 20.1" D 55 cm / 21.7"

Sofas & Lounge Chairs



Outline Sofa
2-Seater

Outline Sofa
3-Seater

Outline Sofa
3,5-Seater

Outline Sofa
Chaise Longue

Outline Sofa
Corner

Outline Chair



Outline Pouf

Outline daybed

Connect Soft
Modular Sofa
2-Seater

Connect Soft
Modular Sofa
3-Seater

Connect Soft
Modular Sofa
Corner

Connect
Modular Sofa
2-Seater



Connect
Modular Sofa
3-Seater

Connect
Modular Sofa
Corner

In Situ Modular Sofa
2-Seater

In Situ Modular Sofa
3-Seater

In Situ Modular Sofa
4-Seater

In Situ Modular Sofa
Corner

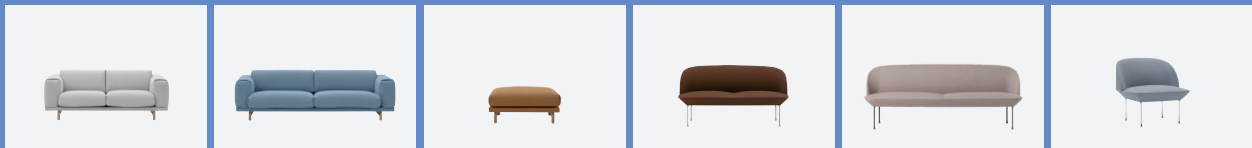

Rest Sofa
2-Seater

Rest Sofa
3-Seater

Rest Pouf

Oslo Sofa
2-Seater

Oslo Sofa
3-Seater

Oslo Sofa
1-Seater

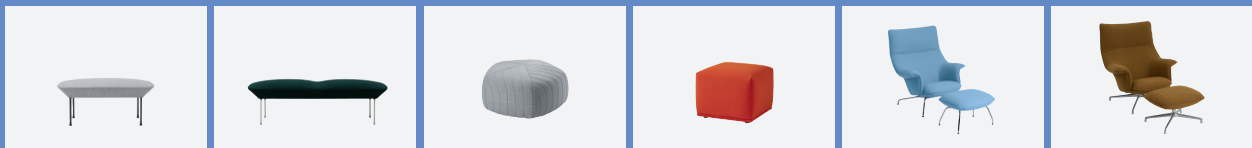

Oslo Pouf

Oslo Bench

Five Pouf

Echo Pouf

Doze Lounge Chair
High Back
—Tube Base

Doze Lounge Chair
High Back
—Swivel Base



Doze Lounge Chair
Low Back
—Tube Base

Doze Lounge Chair
Low Back
—Swivel Base

Wrap Lounge Chair

Oslo Lounge Chair
—Tube Base

Oslo Lounge Chair
—Swivel Base

Fiber Lounge Armchair
—Wood Base



Fiber Lounge Armchair
—Tube Base

Fiber Lounge Chair
—Wood Base

Fiber Lounge Chair
—Tube Base

Cover Lounge Chair

Visu Lounge Chair

Outline Sofa
by Anderssen & Voll



Material
Wood and steel construction with cold foam filling. Outer in textile or leather upholstery. Powder-coated or polished aluminum legs.

Additional Information
The majority of the Outline Sofa Series is Made-To-Order. Explore all Made-To-Order options on muuto.com/products. Please note that Outline Daybed and Outline Sofa 3 1/2-Seater are available in Refine Leather Cognac / Black as Ready-To-Ship Option.

Ready-To-Ship Options (3-, 2-Seater & Chair)

(Textile Upholstery / Base)
Remix 163 / Black



Ecriture 240 / Polished Aluminum



Clay 12 / Black



(Leather Upholstery / Base)
Refine Leather Cognac / Black



Configurable				H 71 cm / 28" SH 40 cm / 15.7"
3 1/2-Seater W 255 cm / 100.4" SW 235 cm / 92.5"		D 84 cm / 33.1" SD 62 cm / 24.4"		
		H 71 cm / 28" SH 40 cm / 15.7"		
Chaise Longue W 263 cm / 103.5" W 95 cm / 37.4"		D 142 cm / 55.9" SD 122 cm / 45"		
		H 71 cm / 28" SH 40 cm / 15.7"		
Corner W 255 cm / 100.4" SW 220 cm / 86.6"		D 255 cm / 100.4"		
		H 40 cm / 15.7"		
Daybed W 200 cm / 78.8"		D 82 cm / 32.3"		
		H 40 cm / 15.7"		
Pouf W 111 cm / 43.7"		D 78 cm / 30.7"		
		H 71 cm / 28" SH 40 cm / 15.7"		
Studio 220 cm W 220 cm / 86.6" SW 200 cm / 78.7"		D 76 cm / 29.9" SD 54 cm / 21.3"		
		H 71 cm / 28" SH 40 cm / 15.7"		
Studio 170 W 170 cm / 66.9" SW 150 / 59.1"		D 76 cm / 29.9" SD 54 cm / 21.3"		
		H 71 cm / 28" SH 40 cm / 15.7"		
Studio 140 cm W 140 cm / 55" SW 120 cm / 47.2"		D 76 cm / 29.9" SD 54 cm / 21.3"		
		H 71 cm / 28" SH 40 cm / 15.7"		
Studio Chair W 78 cm / 30.7" SW 60 cm / 23.6"		D 76 cm / 29.9" SD 54 cm / 21.3"		
		H 71 cm / 28" SH 40 cm / 15.7"		
3-Seater W 220 cm / 86.6" SW 200 cm / 78.7"		D 84 cm / 33.1" SD 62 cm / 24.4"		
		H 71 cm / 28" SH 40 cm / 15.7"		
2-Seater W 170 cm / 66.9" SW 150 / 59.1"		D 84 cm / 33.1" SD 62 cm / 24.4"		
		H 71 cm / 28" SH 40 cm / 15.7"		
Chair W 88 cm / 34.6" SW 70 cm / 27.6"		D 84 cm / 33.1" SD 62 cm / 24.4"		

Connect Soft Modular Sofa
by Anderssen & Voll



Material

Seat and back frame made in FSC™-certified wood. Back frame is covered with cold-foam filling and wadding. Seat is made with zig-zag springs, felt, cold-foam and wadding. The module is upholstered in high-quality textiles, imitation leather or leather with a thin lining of wadding underneath. Modules are kept together with connecting metal brackets.

Ready-To-Ship Options

(Textile Upholstery)

Re-Wool 128



Clay 12



The mark of responsible forestry
FSC™ C028824



W 104,5 cm / 41.14"
SW 75,5 cm / 29.72"



W 104,5 cm / 41.14"
SW 75,5 cm / 29.72"



W 104,5 cm / 41.14"

D 99 cm / 38.98"
SD 66 cm / 25.98"
SH 40 cm / 15.75"



W 104,5 cm / 41.14"



W 83 cm / 32.68"



W 99 cm / 38.98"
SW 66 cm / 25.98"

D 99 cm / 38.98"
SD 66 cm / 25.98"
SH 40 cm / 15.75"

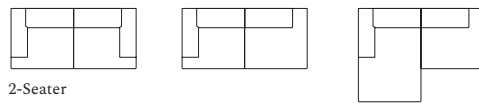

2-Seater

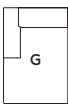

W 104,5 cm / 41.14"
SW 75,5 cm / 29.72"

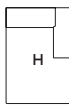

W 104,5 cm / 41.14"
SW 75,5 cm / 29.72"

D 154,5 cm / 60.83"
SD 125 cm / 49.21"
SH 40 cm / 15.75"

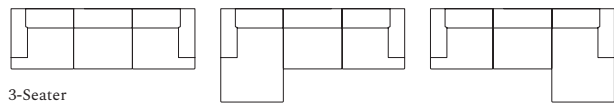

3-Seater



W 99 cm / 38.98"

D 99 cm / 38.98"
SD 66 cm / 25.98"
SH 40 cm / 15.75"

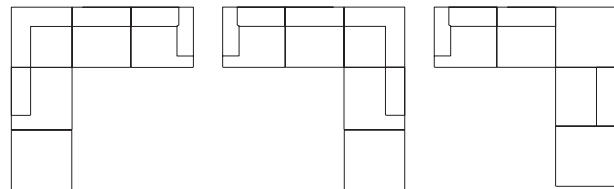

Corner



W 64 cm / 25.2"



D 11 cm / 4.3"

H 22 cm / 8.66"

Inspiration for your Connect Soft Modular Sofa

Choose from 9 predefined configurations or create your own Connect Soft Modular Sofa on planner.muuto.com

Connect Modular Sofa
by Anderssen & Voll



Material

Seat and back frame are made of wood. The back frame is covered with cold foam filling and cotton wadding. The seat is made with zig-zag springs, felt, cold foam, and cotton wadding. Each module is upholstered in high-quality textiles or imitation leather and is kept together with connecting metal brackets.

Additional Information

Please note that the modules H & I can only be used as a freestanding ottoman and not part of the sofa configuration.

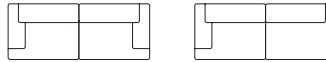

2-Seater

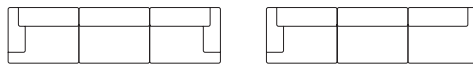

3-Seater

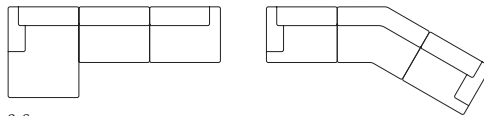

3-Seater

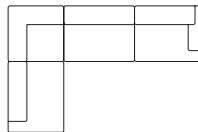

Corner



W 118,5 cm / 46.65"
SW 88 cm / 34.65"



W 118,5 cm / 46.65"
SW 88 cm / 34.65"



W 118,5 cm / 46.65"

D 98 cm / 38.58"
SD 64 cm / 25.20"
SH 42 cm / 16.54"



W 94,5 cm / 37.20"



W 98 cm / 38.58"

D 98 cm / 38.58"
SD 64 cm / 25.20"
SH 42 cm / 16.54"



W 118,5 cm / 46.65"



W 118,5 cm / 46.65"

D 98 cm / 38.58"
SD 64 cm / 25.20"
SH 42 cm / 16.54"



W 118,5 cm / 46.65"



98 cm / 38.58"

D 98 cm / 38.58"
SH 42 cm / 16.54"



W 118,5 cm / 46.65"
SW 88 cm / 34.65"



W 118,5 cm / 46.65"
SW 88 cm / 34.65"

D 155 cm / 61.02"
SD 122 cm / 48.03"
SH 42 cm / 16.54"



W 158 cm / 62.20"
SW 144 cm / 56.69"

D 113 cm / 44.49"
SD 64 cm / 25.20"
SH 42 cm / 16.54"



W 158 cm / 62.20"
SW 125 cm / 49.21"

D 113 cm / 44.49"
SD 64 cm / 25.20"
SH 42 cm / 16.54"



W 196 cm / 77.17"
SW 196 cm / 77.17"

D 68 cm / 26.77"
SD 68 cm / 26.77"
SH 42 cm / 16.54"

Inspiration for your Connect Modular Sofa
Create your own Connect Modular Sofa on planner.muuto.com

In Situ Modular Sofa
by Anderssen & Voll



Material

Frame in powder-coated steel. Modules in an FSC™-certified wood construction with foam and wadding. Fully upholstered with textile, imitation leather, or leather. Leather from selected premium leather suppliers. The inside of the In Situ Cushion features a foam core with a pillowcase filled with fiber balls.

Ready-To-Ship Options

(Textile Upholstery / Base)
Clay 12 / Black



Ecriture 240 / Black



The mark of responsible forestry
FSC® C028824



W 99 cm / 39"
SW 81 cm / 32.9"



W 99 cm / 39"
SW 81 cm / 32.9"

D 107 cm / 42.1"
SD 74 cm / 29.2"
SH 38 cm / 15"



W 81 cm / 32.9"



W 81 cm / 32.9"

D 99 cm / 39"



W 107 cm / 42.1"
SW 74 cm / 29.2"

D 107 cm / 42.1"
SD 74 cm / 29.2"
SH 38 cm / 15"



W 99 cm / 39"



W 99 cm / 39"

D 107 cm / 42.1"
SD 74 cm / 29.2"
SH 38 cm / 15"

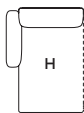

W 117 cm / 46"
SW 99 cm / 39"

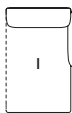

W 117 cm / 46"
SW 99 cm / 39"

D 169 cm / 66.5"
SD 136 cm / 53.6"
SH 38 cm / 15"



W 70 cm / 27.6"
D 50 cm / 19.7"



W 70 cm / 27.6"
D 30 cm / 11.8"

H 18 cm / 7.1"
H 14 cm / 5.5"

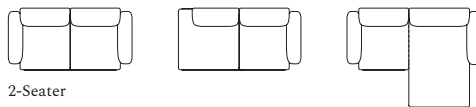

2-Seater

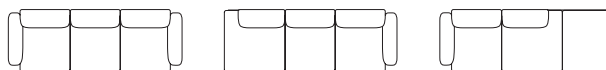

3-Seater

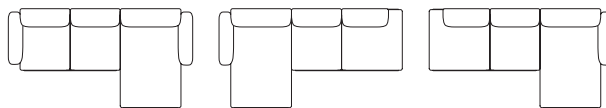

3-Seater



4-Seater

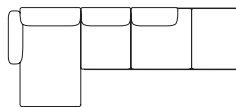

4-Seater

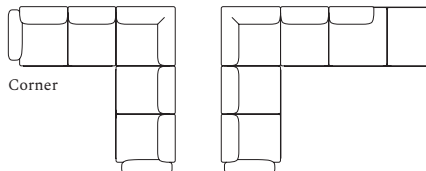

Corner

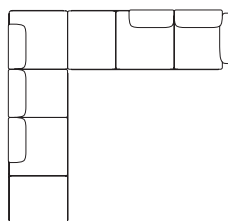

Corner

Inspiration for your In Situ Modular Sofa

Choose from 30 predesigned configurations or create your own on planner.muuto.com

Rest Sofa Series
by Anderssen & Voll



Material
Frame and legs are made in FSC™-certified wood. Frame in plywood and High-Density Fiberboard (HDF), zig-zag springs, cold foam, and wadding. Upholstered in high-quality textiles. Legs in natural solid oak. EU/US version: Standard and high-resilience polyurethane foam. UK version: Standard fire retardant polyurethane and combustion-modified high resilience foam.

Additional Information
This product is Made-To-Order. Explore all Made-To-Order options on muuto.com/products.

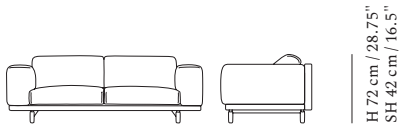

3-Seater
W 260 cm / 102.5"
SW 207 cm / 81.5"

D 92 cm / 36.25"
SD 60 cm / 23.6"

H 72 cm / 28.75"
SH 42 cm / 16.5"

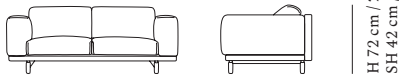

2-Seater
W 200 cm / 78.75"
SW 147 cm / 58"

D 92 cm / 36.25"
SD 60 cm / 23.6"

H 72 cm / 28.75"
SH 42 cm / 16.5"



Studio Sofa
W 165 cm / 65"
SW 122 cm / 48"

D 87 cm / 34.25"
SD 55 cm / 21.75"

H 72 cm / 28.75"
SH 42 cm / 16.5"



Pouf
W 100 cm / 39.5"

D 80 cm / 31.5"

H 42 cm / 16.5"

Oslo Sofa Series
by Anderssen & Voll



Material
Seat and back in molded PU Foam with embedded steel frames and zig-zag springs. Fully upholstered with textile, imitation leather, or leather. Leather from selected premium leather suppliers. Legs in chromed or powder-coated steel with felt glides.

Additional Information
This product is Made-To-Order. Explore all Made-To-Order options on muuto.com/products.



3-Seater
W 200 cm / 78.75"

D 73 cm / 28.75"
SD 54 cm / 21.25"

H 79.5 cm / 31.3"
SH 45 cm / 17.7"



2-Seater
W 150 cm / 59"

D 73 cm / 28.75"
SD 54 cm / 21.25"

H 79.5 cm / 31.3"
SH 45 cm / 17.7"



1-Seater
W 80 cm / 31.5"

D 73 cm / 28.75"
SD 54 cm / 21.25"

H 79.5 cm / 31.3"
SH 45 cm / 17.7"



Bench
W 150 cm / 59"

D 73 cm / 28.75"

H 45 cm / 17.7"



Pouf
W 100 cm / 39.5"

D 73 cm / 28.75"

H 45 cm / 17.7"

Five Pouf
by Anderssen & Voll



Material
Wooden frame and molded foam. Outer in textile upholstery.

Additional Information
This product is Made-To-Order. Explore all Made-To-Order options on muuto.com/products.

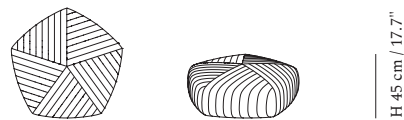

Extra Large
W 140 cm / 55"

W per side 85 cm / 33.5"

H 45 cm / 17.7"

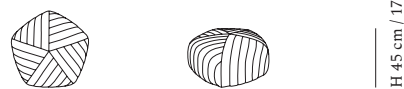

Large
W 88 cm / 34.5"

W per side 53 cm / 21"

H 45 cm / 17.7"

Echo Pouf
by Anderssen & Voll



Material
Wooden frame and high-resilience foam. Outer in textile upholstery.

Additional Information
This product is Made-To-Order. Explore all Made-To-Order options on muuto.com/products.

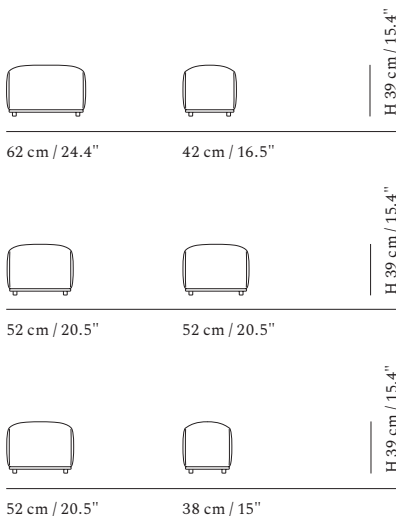

Doze Lounge Chair High Back
& Ottoman — Tube Base
by Anderssen & Voll



Material
Made from metal, foam, and wadding and finished with textile, imitation leather, or leather upholstery. The leather comes from selected premium leather suppliers. Please note that the upholstery cannot be removed. Tube base in chromed or powder-coated steel. Plastic glides in black.

- Ready-To-Ship Options**
(Textile Upholstery / Base)
- Ocean 80 / Anthracite Black
 - Hearth 7 / Grey
- (Leather Upholstery / Base)
- Refine Leather Cognac / Anthracite Black

Explore all Made-To-Order options on muuto.com/products.

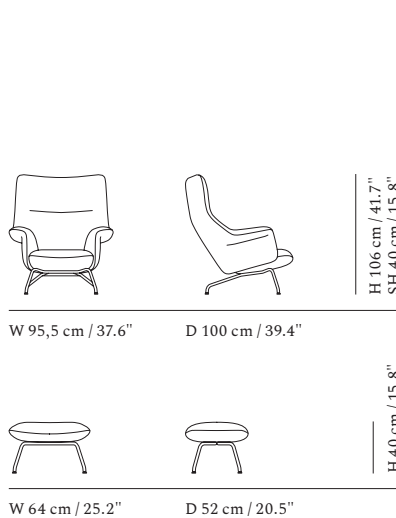

Doze Lounge Chair High Back
& Ottoman — Swivel Base
by Anderssen & Voll



Material
Made from metal, foam, and wadding and finished with textile, imitation leather, or leather upholstery. The leather comes from selected premium leather suppliers. Please note that the upholstery cannot be removed. Swivel base in polished or powder-coated casted aluminum. Plastic glides in black.

- Ready-To-Ship Options**
(Textile Upholstery / Base)
- Ocean 80 / Anthracite Black
- (Leather Upholstery / Base)
- Refine Leather Cognac / Anthracite Black

Explore all Made-To-Order options on muuto.com/products.

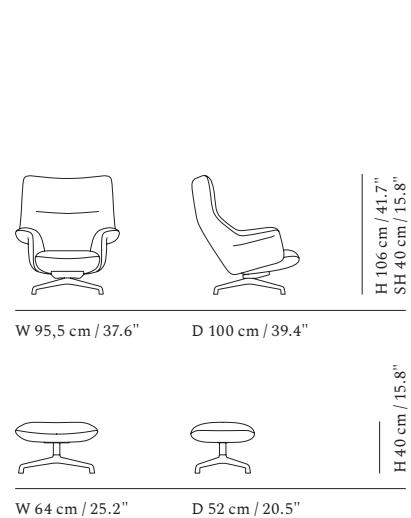

Doze Lounge Chair Low Back
— Tube Base
by Anderssen & Voll



Material
Made from metal, foam, and wadding and finished with textile, imitation leather, or leather upholstery. The leather comes from selected premium leather suppliers. The Doze Lounge Chair—Low Back is upholstered in molded foam with an embedded steel frame. Please note that the upholstery cannot be removed. Tube base in chromed or powder-coated steel. Plastic glides in black.

Ready-To-Ship Options
(Textile Upholstery / Base)
Hearth 7 / Grey



Ocean 80 / Anthracite Black



(Leather Upholstery / Base)
Refine Leather Cognac / Anthracite Black



Explore all Made-To-Order options on muuto.com/products.

Doze Lounge Chair Low Back
— Swivel Base
by Anderssen & Voll



Material
Made from metal, foam, and wadding and finished with textile, imitation leather, or leather upholstery. The leather comes from selected premium leather suppliers. The Doze Lounge Chair—Low Back is upholstered in molded foam with an embedded steel frame. Please note that the upholstery cannot be removed. Swivel base in polished or powder-coated casted aluminum. Plastic glides in black.

Ready-To-Ship Options
(Textile Upholstery / Base)
Hearth 7 / Grey



Ocean 80 / Anthracite Black



(Leather Upholstery / Base)
Refine Leather Cognac / Anthracite Black



Explore all Made-To-Order options on muuto.com/products.

Wrap Lounge Chair
by Normal Studio



Material
Interior shell made of pressed felt from 100% recycled post-consumer plastic with a steel reinforcement. Wrap Lounge Chair's shell is clad with multiple layers of foam and wadding and finished with textile upholstery. Upholstered in high-quality textiles from Kvadrat and Rohleder. Tube base in powder-coated steel with plastic glides.

Ready-To-Ship Options

(Shell / Base)
Sabi 151 / Black



Ecriture 240 / Grey



Explore all Made-To-Order options on muuto.com/products.



W 95,5cm / 37.6" D 86 cm / 33.9"



W 95,5cm / 37.6" D 86 cm / 33.9"



W 64 cm / 25.2" D 52 cm / 20.5"



W 64 cm / 25.2" D 52 cm / 20.5"

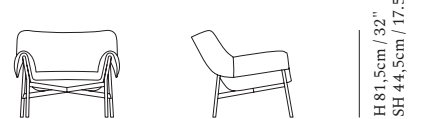

W 91,3 cm / 35.95" D 91 cm / 35.83"

Oslo Lounge Chair – Tube Base
by Anderssen & Voll



Material
Seat and back in molded PU foam with embedded steel and wood frame. Textile upholstery. Tube base in powder-coated-steel with plastic gliders.

Ready-To-Ship Options
(Textile Upholstery / Base)
Vidar 146 / Grey



Twill Weave 990 / Black



Explore all Made-To-Order options on muuto.com/products.

Oslo Lounge Chair – Swivel Base
by Anderssen & Voll



Material
Seat and back in molded PU Foam with embedded steel and wood frame. Textile upholstery. Swivel base in powder-coated steel with plastic gliders.

Ready-To-Ship Options
(Textile Upholstery / Base)
Vidar 146 / Grey



Twill Weave 990 / Black



Explore all Made-To-Order options on muuto.com/products.

Fiber Lounge Armchair – Wood Base
by Iskos-Berlin



Material
The shell is made using 100% recycled plastic mixed with strength-improving additives. The recycled plastic comes from post-consumer waste. The shell is clad with foam and wadding and finished with a high-quality textile, imitation leather, or leather upholstery. Wood base in FSC™-certified solid oak with water-based lacquer. For the Stained Dark Brown version slight color variations can occur. Plastic glides.

Ready-To-Ship Options
(Textile Upholstery / Base)
Ecriture 240 / Oak



(Leather Upholstery / Base)
Refine Leather Cognac / Anthracite Black



Explore all Made-To-Order options on muuto.com/products.



The mark of responsible forestry
FSC™ C028624

Made with recycled materials

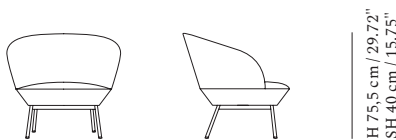

W 82,5 cm / 32.48" D 67,5 cm / 26.57"

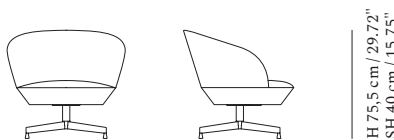

82,5 cm / 32.48" D 67,5 cm / 26.57"

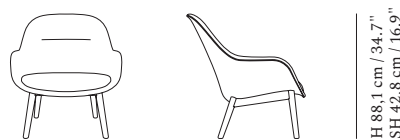

W 75 cm / 29.5" D 83,3 cm / 32.8"

Fiber Lounge Armchair – Tube Base by Iskos-Berlin



Material

The shell is made using 100% recycled plastic mixed with strength-improving additives. The recycled plastic comes from post-consumer waste. The shell is clad with foam and wadding and finished with a high-quality textile, imitation leather, or leather upholstery. Tube base in powder-coated steel. Plastic glides.

Ready-To-Ship Options (Textile Upholstery / Base)

Ecriture 240 / Grey



(Leather Upholstery / Base)

Refine Leather Cognac / Anthracite Black



Explore all Made-To-Order options on muuto.com/products.



Made with recycled materials

Fiber Lounge Chair – Wood Base by Iskos-Berlin



Material

Shell without upholstery: 100% recycled plastic reinforced with strength-improving additives and mixed with up to 25% FSC™-certified wood fibers. Shell with upholstery: 100% recycled plastic reinforced with strength-improving additives and mixed with up to 25% wood fibers. Shell can be fully upholstered with textile, imitation leather, or leather. Leather from selected premium leather suppliers. Due to the partly natural material of the shell, slight color variations can occur. Wood base in FSC™-certified oak with water-based lacquer. For the Stained Dark Brown version slight color variations can occur. Plastic glides. The Fiber Series without upholstery is EU Ecolabel Certified.

Additional Information

This product is Made-To-Order. Explore all Made-To- Order options on muuto.com/products.



The mark of responsible forestry
FSC® C028824



Made with recycled materials

Fiber Lounge Chair – Tube Base by Iskos-Berlin



Material

Shell without upholstery: 100% recycled plastic reinforced with strength-improving additives and mixed with up to 25% FSC™-certified wood fibers. Shell with upholstery: 100% recycled plastic reinforced with strength-improving additives and mixed with up to 25% wood fibers. Shell can be fully upholstered with textile, imitation leather, or leather. Leather from selected premium leather suppliers. Due to the partly natural material of the shell, slight color variations can occur. Tube base in powder-coated steel. The Fiber Series without upholstery is EU Ecolabel Certified.

Additional Information

This product is Made-To-Order. Explore all Made-To- Order options on muuto.com/products.



The mark of responsible forestry
FSC® C028824



Made with recycled materials



H 88,1 cm / 34.7"
SH 42,8 cm / 16.9"



H 74,4 cm / 29.3"
SH 38 cm / 15"



H 74,4 cm / 29.3"
SH 38 cm / 15"

W 75 cm / 29.5"

D 83,3 cm / 32.8"

W 60 cm / 23.6"

D 69 cm / 27.2"

W 60 cm / 23.6"

D 69 cm / 27.2"

Cover Lounge Chair by Thomas Bentzen



Material

Back and seat in oak veneer, solid oak frame and legs with water-based lacquer. Upholstered seat with textile or leather. For Oak and Stained Dark Brown version slight color variations can occur. The Cover Series without upholstery is EU Ecolabel Certified.

Ready-To-Ship Options (Shell / Base)

Oak 

Stained Dark Brown 

Black 

(Leather Upholstery / Base)
Refine Leather Cognac / Oak 

Refine Leather Black / Black 

Explore all Made-To-Order options on muuto.com/products.



Visu Lounge Chair by Mika Tolvanen



Material

Oak version: Shell and base in oak veneer. Colored version: shell and base in ash veneer. Both in water-based lacquer. Fully upholstered shell in textile or leather. For Oak version slight color variations can occur.

Ready-To-Ship Options (Shell / Base)

Oak / Oak 

Black / Black 

Grey / Grey 

Dusty Green / Dusty Green 

Explore all Made-To-Order options on muuto.com/products.



W 66,3 cm / 26.1"



D 61,2 cm / 24.1"

H 70,7 cm / 27.8"
H armrest 57,8 cm / 22.8"
SH 38,1 cm / 15"



W 60 cm / 23.5"



D 51 cm / 20"

H 69 cm / 27.25"
SH 40 cm / 15.75"

Tables



70/70 Table



Earnest Extendable Table



Midst Table



Linear Wood Series
Table & Bench



Workshop Table



Base Table



Base Round Table



Base High Table



Soft Table



Soft Café Table



Soft Coffee Table



Soft Side Table



Couple Coffee Table



Workshop Coffee Table



Airy Coffee Table



Around Coffee Table



Relate Side Table

70/70 Table
by TAF Studio



Material

Tabletop in lacquered oak veneer, Black and Grey version in plywood with linoleum surface, White version in plywood with laminate surface. Solid Oak or Solid Smoked Oak tabletop in FSC™-certified oak. Frame in powder-coated aluminum. For Oak Veneer version slight color variations can occur.

Ready-To-Ship Options

(Tabletop)

- Oak Veneer / Plywood ●

- Solid Oak ●

- Solid Smoked Oak ●

- White Laminate / Plywood ○

- Black Linoleum / Plywood ●

- Grey Linoleum / Plywood ●

(Frame)

- White ○

- Black ●

- Grey ●

- Sand ●

Explore all options on muuto.com/products.



The mark of
responsible forestry
FSC® C028624

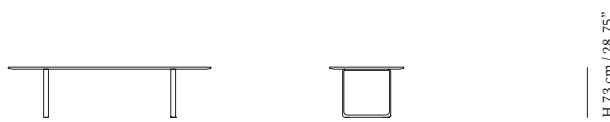

L 295 cm / 116.1"
L btw. legs 176 cm / 69.3"

W 108 cm / 42.5"

H 73 cm / 28.75"

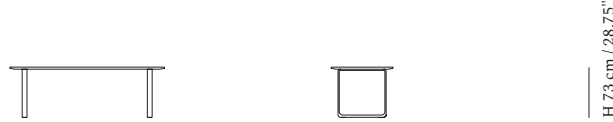

L 225 cm / 88.6"
L btw. legs 175 cm / 68.9"

W 90 cm / 35.4"

H 73 cm / 28.75"



L 255 cm / 100.4"
L btw. legs 205 cm / 80.7"

W 108 cm / 42.5"

H 73 cm / 28.75"

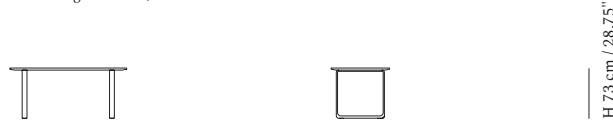

L 170 cm / 67"
L btw. legs 120 cm / 47.2"

W 85 cm / 33.5"

H 73 cm / 28.75"

Earnest Extendable Table
by John Tree



Material

The tabletop and base are made from FSC™-certified solid oak, treated with either a clear or a dark oil. Plastic glides. The extension leaves are made from FSC™-certified solid oak and are treated with either a clear or dark oil.

Ready-To-Ship Options

Oiled Oak ●

Dark Oiled Oak ●

Additional Information

Extension leaves can easily be inserted into each end of the table frame to extend the length of the table. Extension leaves are not included, and can be purchased separately.



L 205 cm / 80.71"
L btw. legs 147,3 cm / 57.99"

W 100 / 39.37"



With extension leaves:
L 293 cm / 115.4"

Extension leaf:
L 44 / 17.32"
W 100 / 39.37"



L 260 cm / 102.36"
L btw. legs 192,3 cm / 75.71"

W 100 / 39.37"



With extension leaves:
L 348 cm / 137"

Extension leaf:
L 44 / 17.32"
W 100 / 39.37"

Midst Table
by TAF Studio



Material

Tabletop in lacquered MDF with a linoleum top or FSC™-certified solid oak, treated with either a clear or dark oil. Base in powder-coated steel with a protective rubber ring under the base.

Additional Information

Other color combinations are available upon request.

Ready-To-Ship Options

(Tabletop / Base)
Black Linoleum / Black ● ●

Dark Red Linoleum / Dark Red ● ●

Dark Oiled Oak / Black ● ●

Dark Oiled Oak / Grey ● ●

Dark Oiled Oak / Dark Red ● ●

Oak / Black ● ●

Oak / Grey ● ●

Oak / Dark Red ● ●

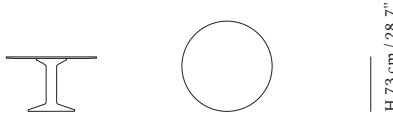

W 62 cm / 24.4"

Ø 120 cm / 47.3"

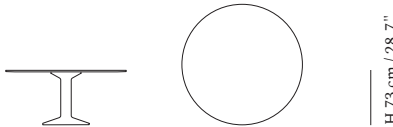

W 62 cm / 24.4"

Ø 160 cm / 62.9"

Linear Wood Series
by Thomas Bentzen



Material

Tabletop in lacquered oak veneer with solid oak legs. Bench seat in lacquered oak veneer with solid oak legs. For Oak Veneer version slight color variations can occur.

Ready-To-Ship Options

Oak Veneer / Oak ●



L 260 cm / 102.4"
L btw. legs 235 cm / 92.5"

W 95,3 cm / 37.5"
W Tabletop 90 cm / 35.4"

H 74 cm / 29.1"



L 200 cm / 78.7"
L btw. legs 175 cm / 68.9"

W 95,3 cm / 37.5"
W Tabletop 90 cm / 35.4"

H 74 cm / 29.1"



L 140 cm / 55.1"
L btw. legs 115 cm / 45.3"

W 90,3 cm / 35.5"
W Tabletop 85 cm / 31.5"

H 74 cm / 29.1"



L 170 cm / 67"

W 39,4 cm / 15.5"
W Bench Top 34 cm / 13.4"

H 46 cm / 18.1"

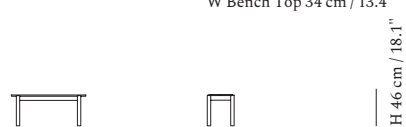

L 110 cm / 43.3"

W 39,4 cm / 15.5"
W Bench Top 34 cm / 13.4"

H 46 cm / 18.1"

Workshop Table
by Cecilie Manz



Material
Tabletop in oak veneer or linoleum. Frame and legs from solid oak. Both versions with either black or clear matte water-based lacquer. For Oak Veneer version slight color variations can occur.

Additional Information
Please note that size 130 x 65 cm is not available in Oak Veneer / Oak.

- Ready-To-Ship Options**
(Tabletop / Frame)
- Oak Veneer / Oak
 - Warm Grey Linoleum / Oak
 - Black Linoleum / Black

Base Table
by Mika Tolvanen



Material
Tabletop in plywood with either laminate, linoleum or oak veneer surface with a water-based lacquer. Plywood or ABS edges. Frame and legs in powder-coated aluminum. For Oak Veneer version slight color variations can occur.

- Ready-To-Ship Options**
(Tabletop)
- Lacquered Oak Veneer / Plywood
 - White Laminate / Plywood
 - White Laminate / ABS
 - Black Linoleum / Plywood
- (Frame)
- White
 - Black

Explore all Made-To-Order options on muuto.com/products.

Base High Table
by Mika Tolvanen



Material
Tabletop in plywood with either laminate, linoleum or oak veneer surface with a water-based lacquer. Plywood or ABS edges. Frame and legs in powder-coated aluminum. For Oak Veneer version slight color variations can occur.

- Ready-To-Ship Options**
(Tabletop)
- Lacquered Oak Veneer / Plywood
 - White Laminate / Plywood
 - White Laminate / ABS
 - Black Linoleum / Plywood
- (Frame)
- White
 - Black

Explore all Made-To-Order options on muuto.com/products.

<p>L 200 cm / 78.7" W 92 cm / 36.2" L btw. legs 190 cm / 74.8" H 73 cm / 28.7"</p>	<p>L 190 cm / 74.8" W 85 cm / 33.5" L btw. legs 181 cm / 71.3" H 73 cm / 28.7"</p>	<p>L 190 cm / 74.75" W 85 cm / 33.5" L btw. legs 181cm / 71.3" H 105 cm / 41.25"</p>
<p>L 140 cm / 55.1" W 92 cm / 36.2" L btw. legs 130 cm / 51.2" H 73 cm / 28.7"</p>	<p>L 140 cm / 55.1" W 80 cm / 31.5" L btw. legs 131 cm / 51.6" H 73 cm / 28.75"</p>	<p>L 190 cm / 74.75" W 50 cm / 19.75" L btw. legs 181cm / 71.3" H 105 cm / 41.25"</p>
<p>L 130 cm / 51.2" W 65 cm / 25.6" L btw. legs 120 cm / 47.2" H 73 cm / 28.7"</p>	<p>L 54,5 cm / 21.5" W 80 cm / 31.5" L btw. legs 74,5 cm / 29.25" H 73 cm / 28.75"</p>	<p>L 190 cm / 74.75" W 85 cm / 33.5" L btw. legs 181cm / 71.3" H 95 cm / 37.5"</p>
<p>L 130 cm / 51.2" W 65 cm / 25.6" L btw. legs 120 cm / 47.2" H 73 cm / 28.7"</p>	<p>L 54,5 cm / 21.5" W 80 cm / 31.5" L btw. legs 74,5 cm / 29.25" H 73 cm / 28.75"</p>	<p>L 190 cm / 74.75" W 50 cm / 19.75" L btw. legs 181cm / 71.3" H 95 cm / 37.5"</p>

Soft Table
by Jens Fager



Material

Base is made from powder-coated, die-casted aluminum (made with at least 97% recycled aluminum) and comes with pre-mounted glides. Tabletop in MDF with nanolaminate (Black), laminate (Beige Green) or linoleum (Grey) surface, in Solid Oak or in Solid Dark Oiled Oak. Laminate, Solid Oiled Oak and Solid Dark Oiled Oak tabletops are made using FSC™-certified wood.

Ready-To-Ship Options

(Tabletop / Base)

Black Nanolaminate / Black	● ●
Grey Linoleum / Grey	● ●
Solid Oak / Grey	● ●
Dark Oiled Oak / Black	● ●
Beige Green Laminate / Beige Green	● ●



The mark of responsible forestry
FSC® C028824

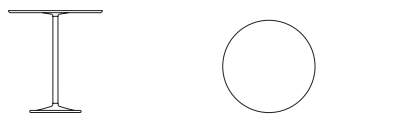

H 105 cm / 41.3" Ø 95 cm / 37.4"

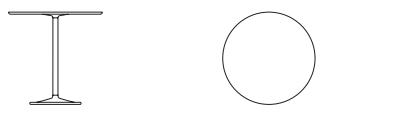

H 95 cm / 37.4" Ø 95 cm / 37.4"

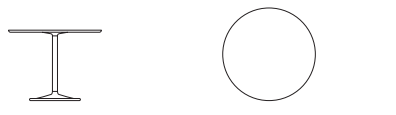

H 73 cm / 28.7" Ø 95 cm / 37.4"

Soft Café Table
by Jens Fager



Material

Base is made from powder-coated, die-casted aluminum (made with at least 97% recycled aluminum) and comes with pre-mounted glides. Tabletop in MDF with nanolaminate (Black), laminate (Beige Green) or linoleum (Grey) surface, in Solid Oak or in Solid Dark Oiled Oak. Laminate, Solid Oiled Oak and Solid Dark Oiled Oak tabletops are made using FSC™-certified wood.

Ready-To-Ship Options

(Tabletop / Base)

Black Nanolaminate / Black	● ●
Grey Linoleum / Grey	● ●
Solid Oak / Grey	● ●
Dark Oiled Oak / Black	● ●
Beige Green Laminate / Beige Green	● ●



The mark of responsible forestry
FSC® C028824

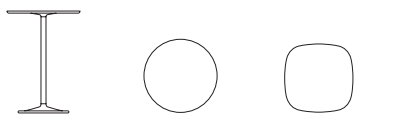

H 105 cm / 41.3" Ø 75 cm / 29.5" D 70 x 70 cm / 27.6 x 27.6"

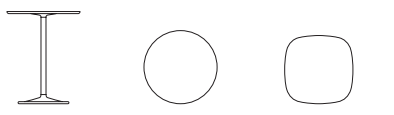

H 95 cm / 37.4" Ø 75 cm / 29.5" D 70 x 70 cm / 27.6 x 27.6"

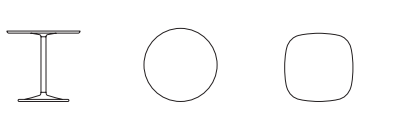

H 73 cm / 28.7" Ø 75 cm / 29.5" D 70 x 70 cm / 27.6 x 27.6"

Soft Coffee Table
by Jens Fager

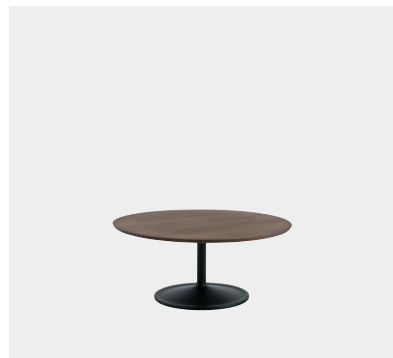

Material

Base is made from powder-coated, die-casted aluminum (made with at least 97% recycled aluminum) and comes with pre-mounted glides. Tabletop in MDF with nanolaminate (Black), laminate (Beige Green) or linoleum (Grey) surface, in Solid Oak or in Solid Dark Oiled Oak. Laminate, Solid Oiled Oak and Solid Dark Oiled Oak tabletops are made using FSC™-certified wood.

Ready-To-Ship Options

(Tabletop / Base)

Black Nanolaminate / Black	● ●
Grey Linoleum / Grey	● ●
Solid Oak / Grey	● ●
Dark Oiled Oak / Black	● ●
Beige Green Laminate / Beige Green	● ●



The mark of responsible forestry
FSC® C028824



H 42 cm / 16.5" D 70 x 70 cm / 27.6 x 27.6"

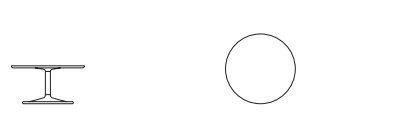

H 42 cm / 16.5" Ø 75 cm / 29.5"

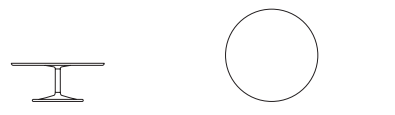

H 42 cm / 16.5" Ø 95 cm / 37.4"

Soft Side Table
by Jens Fager



Material

Base is made from powder-coated, die-casted aluminum (made with at least 97% recycled aluminum) and comes with pre-mounted glides. Tabletop in MDF with nanolaminate (Black), laminate (Beige Green, Orange) or linoleum (Grey) surface, in Solid Oiled Oak or in Solid Smoked Oak. Laminate, Solid Oiled Oak and Solid Smoked Oak tabletops are made using FSC™-certified wood. The Soft Side Table with Solid Oak and Laminate top are EU Ecolabel Certified.

Ready-To-Ship Options
(Tabletop / Base)

Black Nanolaminate / Black	 
Orange Laminate / Orange	 
Oiled Smoked Oak / Black	 
Oiled Oak / Grey	 
Grey Linoleum / Grey	 
Beige-Green Laminate / Beige-Green	 









Couple Coffee Table
by Sylvain Willenz



Material

Tabletop tiles made of ceramic stoneware treated with a stone sealer for extra stain protection. Tiles are placed loosely on top of the frame with rubber anti-slip pads securing the tiles in place. Frame in solid oak treated with either clear or dark oil, made using FSC™-certified wood. Premounted felt glides.

Ready-To-Ship Options
(Tabletop / Frame)

Sand / Oak	 
Sand / Dark Oiled Oak	 
Light Blue / Oak	 
Light Blue / Dark Oiled Oak	 
Taupe / Oak	 
Taupe / Dark Oiled Oak	 

Explore all 36 variants on muuto.com



The mark of responsible forestry
FSC™ C028824











Workshop Coffee Table
by Cecilie Manz



Material

Tabletop in oak veneer or linoleum. Frame and legs from solid oak. Both versions with either black or clear matte water-based lacquer. For Oak version slight color variations can occur.

Ready-To-Ship Options

(Tabletop / Frame)	 
Oak / Oak	 
Black / Black	 
Warm Grey Linoleum / Oak	 
Black Linoleum / Black	 



H 48 cm / 18.9" H 40 cm / 15.7" D 45 cm / 17.7"



W 120 cm / 47.2" L 84 cm / 33.2" H 35 cm / 13.7"



H 48 cm / 18.9" H 40 cm / 15.7" Ø 48 cm / 18.9"



W 80 cm / 31.5" L 84 cm / 33.2" H 40 cm / 15.7"



L 120 cm / 47.25" W 43 cm / 16.9" H 38 cm / 15"



H 48 cm / 18.9" H 40 cm / 15.7" Ø 41 cm / 15.7"

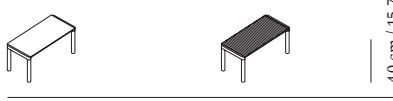

W 40 cm / 15.7" L 84 cm / 33.2" H 40 cm / 15.7"



L 86 cm / 33.9" W 86 cm / 33.9" H 38 cm / 15"

Airy Coffee Table
by Cecilie Manz



Material

Tabletop in plywood with a nanolaminate finish. Frame in powder-coated solid steel.

Ready-To-Ship Options

- Black ●

- Grey ●

- White ●



Large
L 120 cm / 47.2"

W 65 cm / 25.6"

H 41,4 cm / 16.3"



Medium
L 88 cm / 34.6"

W 51,5 cm / 20.3"

H 37,4 cm / 14.7"



Small
L 68 cm / 26.8"

W 44 cm / 17.3"

H 37,4 cm / 14.7"



Half size
L 38,5 cm / 15.2"

W 44 cm / 17.3"

H 37,4 cm / 14.7"

Around Coffee Table
by Thomas Bentzen



Material

Oak and Ash version: Tabletop in oak or ash plywood, solid oak or ash legs. Colored version: Tabletop in MDF or ash plywood, solid ash legs. All versions have a water-based lacquer and in FSC™-certified wood. For Oak and Stained Dark Brown version slight color variations can occur.

Ready-To-Ship Options

- Oak ●

- Ash ●

- Stained Dark Brown ●

- Black ●

- White ●

- Grey ●

- Anthracite ●

- Dark Green ●

- Dusty Green ●

- Light Blue ●

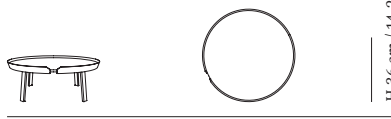

Extra Large
Ø 95 cm / 37.4"

H 36 cm / 14.2"

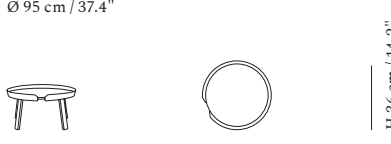

Large
Ø 72 cm / 28.3"

H 36 cm / 14.2"

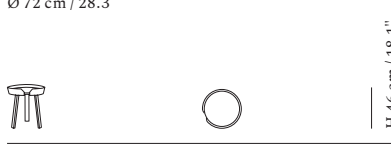

Small
Ø 45 cm / 17.7"

H 46 cm / 18.1"

Relate Side Table
by Big-Game



Material

Tabletop in either Linoleum on MDF, oak laminate on MDF, oiled Solid Oak or oiled Smoked Oak. Frame in powder-coated steel. For Oak Veneer version slight color variations can occur.

Ready-To-Ship Options

- (Tabletop / Base)
- Black ● ●

 - Off-white ● ●

 - Blue-Grey ● ●

 - Dark Green ● ●

 - Solid Oak / Off-White ● ●

 - Solid Smoked Oak / Black ● ●

 - Oak Laminate / Off-White ● ●

 - Oak Laminate / Black ● ●



L 56,2 cm / 22.1"

W 34 cm / 13.4"

H 73,5 cm / 29"



L 56,2 cm / 22.1"

W 34 cm / 13.4"

H 73,5 cm / 29"

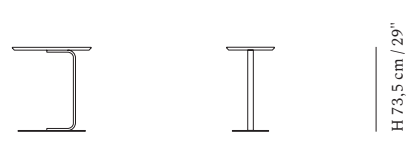

L 56,2 cm / 22.1"

W 34 cm / 13.4"

H 73,5 cm / 29"

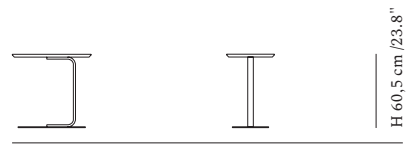

L 56,2 cm / 22.1"

W 34 cm / 13.4"

H 60,5 cm / 23.8"

Outdoor



Linear Steel Table



Linear Steel Café Table



Linear Steel Coffee Table



Linear Steel Bench



Linear Steel Side Chair



Linear Steel Armchair



Linear Lounge Chair



Linear Steel Bar Stool



Outdoor Cover



70/70 Outdoor



Fiber Outdoor Armchair



Fiber Outdoor Side Chair



Piton Portable Lamp



Ease Portable Lamp

Linear Steel Table
by Thomas Bentzen



Material

Frame and tabletop are made from steel with a weather-resistant deep matt, UV-resistant powder-coated finish. Tabletop is aluzinc while legs are galvanized treated, making them suitable for outdoor use. Legs come with plastic glides.

Additional Information
Protective cover available.

Ready-To-Ship Options

- Anthracite Black ●

- Grey ●

- Dark Green ●

- Burnt Orange ●

- Pale Blue ●

Linear Steel Café Table
by Thomas Bentzen



Material

The tabletop and base are made from galvanized steel with a weather-resistant deep matt, UV-resistant powder-coated finish, making the table suitable for outdoor use. Plastic glides for outdoor use.

Ready-To-Ship Options

- Anthracite Black ●

- Grey ●

- Dark Green ●

- Burnt Orange ●

- Pale Blue ●

Linear Steel Coffee Table
by Thomas Bentzen



Material

Tabletop and base made from galvanized steel with a weather-resistant deep matt, UV resistant powder-coated finish, making the table suitable for outdoor use. Plastic glides for outdoor use.

Ready-To-Ship Options

- Anthracite Black ●

- Grey ●

- Dark Green ●

- Burnt Orange ●

- Pale Blue ●



L 220 cm / 86.6" W 95 cm / 37.4"
W Tabletop 90 cm / 35.4"

H 73,5 cm / 28.9"

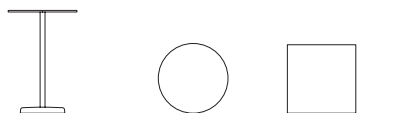

H 105 cm / 41.3" Ø 70 cm / 27.6" W 70 x 70 cm / 27.6" x 27.6"



L 200 cm / 78.7" W 80 cm / 31.5"
W Tabletop 75 cm / 29.5"

H 73,5 cm / 28.9"

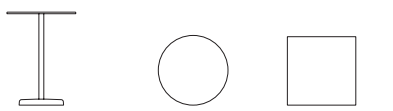

H 95 cm / 37.4" Ø 70 cm / 27.6" W 70 x 70 cm / 27.6" x 27.6"

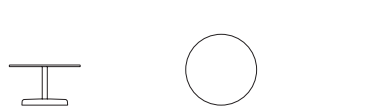

H 40 cm / 15.7" Ø 70 cm / 27.6"

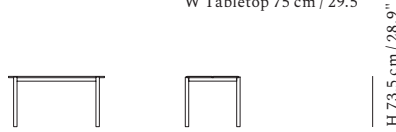

L 140 cm / 55.1" W 80 cm / 31.5"
W Tabletop 75 cm / 29.5"

H 73,5 cm / 28.9"

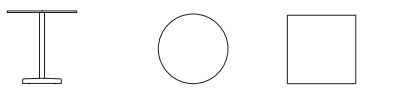

H 73,5 cm / 28.9" Ø 70 cm / 27.6" W 70 x 70 cm / 27.6" x 27.6"

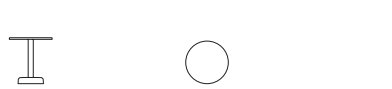

H 47 cm / 18.5" Ø 42 cm / 16.5"

Linear Steel Bench
by Thomas Bentzen



Material

Frame and seat are made from steel with a weather-resistant deep matt, UV-resistant powder-coated finish. Seat is aluzinc while legs are galvanized treated, making them suitable for outdoor use. Legs come with plastic glides.

Additional Information

Seat pad for extended comfort available in Light Grey or Dark Grey.

Ready-To-Ship Options

- Anthracite Black ●

- Grey ●

- Dark Green ●

- Burnt Orange ●

- Pale Blue ●

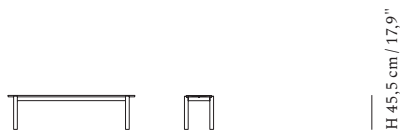

L 170 cm / 67" W 39 cm / 15.4"
W Bench Top 34 cm / 13.4"



L 110 cm / 43,3" W 39 cm / 15.4"
W Bench Top 34 cm / 13.4"

Linear Steel Side Chair
by Thomas Bentzen



Material

The chair is made from galvanized steel with a weather-resistant deep matt, UV-resistant powder-coated finish, making the chair suitable for outdoor use. Plastic glides for outdoor use.

Additional Information

Seat pad for extended comfort available in Light Grey or Dark Grey.

Ready-To-Ship Options

- Anthracite Black ●

- Grey ●

- Dark Green ●

- Burnt Orange ●

- Pale Blue ●



W 49,6 cm / 19,5" D 54 cm / 21,3"

Linear Steel Armchair
by Thomas Bentzen



Material

The chair is made from galvanized steel with a weather-resistant deep matt, UV-resistant powder-coated finish, making the chair suitable for outdoor use. Plastic glides for outdoor use.

Additional Information

Seat pad for extended comfort available in Light Grey or Dark Grey.

Ready-To-Ship Options

- Anthracite Black ●

- Grey ●

- Dark Green ●

- Burnt Orange ●

- Pale Blue ●







W 55,4 cm / 21,8" D 54 cm / 21,3"

Linear Steel Lounge Armchair
by Thomas Bentzen



Material
The lounge armchair is made from galvanized steel with a weather-resistant deep matt, UV-resistant powder-coated finish, making the chair suitable for outdoor use. Plastic glides for outdoor use.

Additional Information
Seat pad for extended comfort available in Light Grey or Dark Grey.

Ready-To-Ship Options	
Anthracite Black	
Grey	
Dark Green	
Burnt Orange	
Pale Blue	

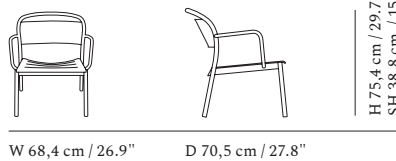





Linear Steel Counter & Bar Stool
by Thomas Bentzen



Material
The Bar & Counter Stool is made from galvanized steel with a weather-resistant deep matt, UV-resistant powder-coated finish, making the chair suitable for outdoor use. Plastic glides for outdoor use.

Additional Information
Seat pad for extended comfort available in Light Grey or Dark Grey.

Ready-To-Ship Options	
Anthracite Black	
Grey	
Dark Green	
Burnt Orange	
Pale Blue	

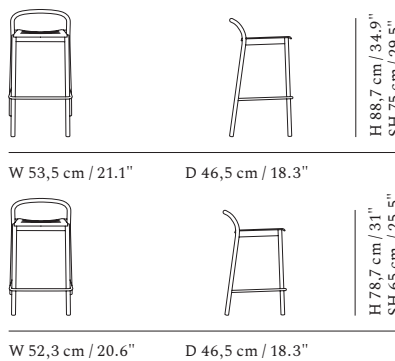

Outdoor Cover



Material
Cover for 200 cm and 140 cm tables in PVC coated Polyester. Cover for 220 cm table in Polyester with TPU membrane.

Additional Information
220 cm: A cover for outdoor furniture groups, allowing one to cover a whole group of a table (220 cm) with up to 6 chairs, keeping them protected from the impact of weather when not in use. Available for Linear Steel Table 220 and 6 Linear Steel Chairs or 70/70 Outdoor Table and 6 Fiber Outdoor Chairs.
200 and 140 cm: A cover for outdoor furniture groups allowing one to cover a group of table (140 & 200 cm) and two benches underneath.

Ready-To-Ship Options	
Black	

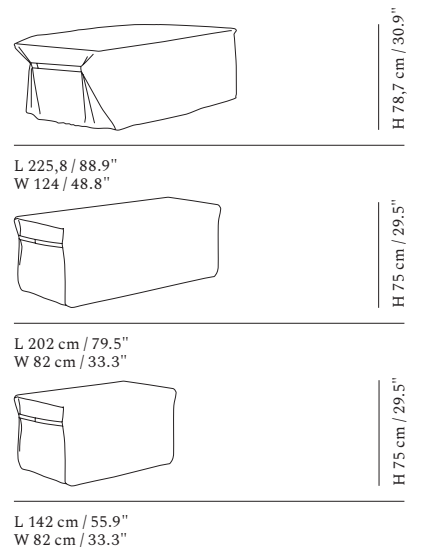

70/70 Outdoor Table
by TAF Studio



Material
Tabletop in FSC™-certified Sapele Mahogany, a durable hardwood. Initially, the tabletop will have a warm glow. If left as is, untreated, the wood will patinate over time and turn a silver shade of grey. Treat the wood with oil for a deeper warm glow and a more reddish expression. Base made from aluminum with a weather-resistant, UV-resistant powder-coated finish. Plastic glides. All materials suitable for outdoor use.

Additional Information
Sapele Mahogany is a natural material where color and wood grain variation can occur from one piece of wood to another. Over time, small cracks at the tip of the wooden planks can occur due to the impact of weather. Furthermore, the wooden planks can, over time, warp a little resulting in a slight height difference between the wooden planks. When exposed to direct sunlight please note that objects placed on the table for a longer period of time can lead to color differences in the tabletop, this will however even itself out over time if the object is removed. Protective cover available.





Ready-To-Ship Options
Sapele Mahogany / Anthracite Black 
Sapele Mahogany / Grey 



Fiber Outdoor Armchair
by Iskos-Berlin







Material
Made using 100% recycled plastic mixed with UV stabilizers that keep color-fading at a minimum, protecting it from the impact of the sun. Tube base in galvanized steel with a weather-resistant deep matte powder coating. Plastic glides for outdoor use.

Ready-To-Ship Options
(Shell / Base)
Anthracite Black / Anthracite Black 
Grey / Grey 
Dusty Green / Dusty Green 
Brown Red / Brown Red 

Fiber Outdoor Side Chair
by Iskos-Berlin



Material
Made using 100% recycled plastic mixed with UV stabilizers that keep color-fading at a minimum, protecting it from the impact of the sun. Tube base in galvanized steel with a weather-resistant deep matte powder coating. Plastic glides for outdoor use.

Ready-To-Ship Options
(Shell / Base)
Anthracite Black / Anthracite Black 
Grey / Grey 
Dusty Green / Dusty Green 
Brown Red / Brown Red 

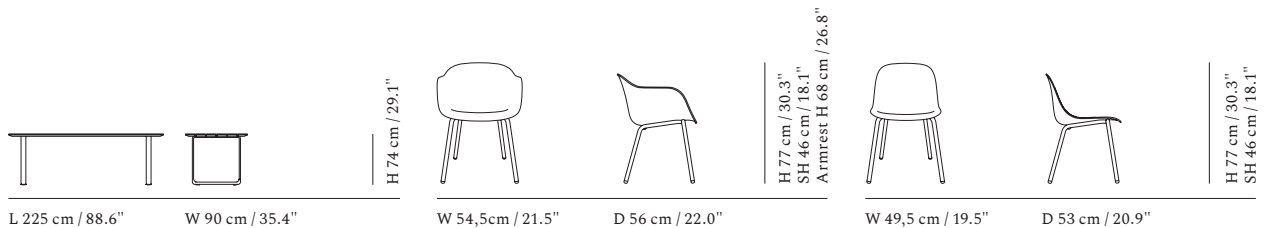

Shelving & Storage



Stacked Storage System
Bookcase 1

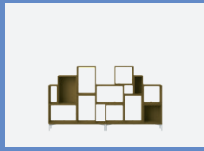

Bookcase 3



Bookcase 8



Sideboard 1

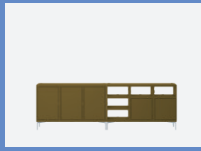

Sideboard 2



Sideboard 3



Hallway 1

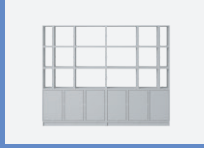

Office 2



Office 4



Bedside 2



Mini Stacked
Storage System
Config. 5



Config 8



Compile
Shelving System
Config 7



Config 8



Reflect Sideboard



Enfold Sideboard



Enfold Sideboard



Flow Trolley



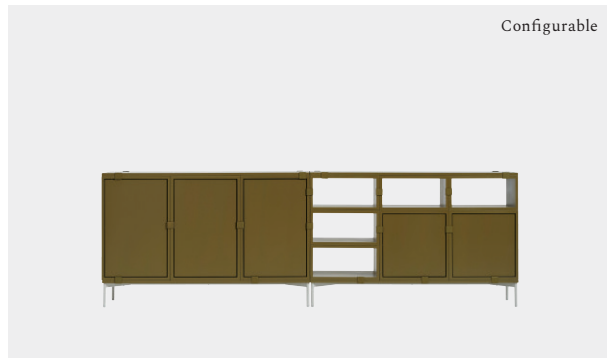

Stacked Storage System by Julien De Smedt



Material







Modules, plinths, and shelves are in PU lacquered MDF or Oak veneered fiberboard. The podium consists of a powder-coated steel frame and a wooden plate made from a PU lacquered MDF or oak veneered fiberboard. Clips are powder-coated bent steel with rubber inserts. The insert is made from bent powder-coated steel with rubber feet.

Ready-To-Ship Options

Oak	
White	
Grey	
Brown Green	
Blue Grey (Insert only)	

Additional information

Each Stacked Storage System module comes with two matching clips, while Oak comes with Grey clips. Extra clips available in Set of 2. Sound absorbing acoustic panels available as add on.

	H 4,1 cm / 1.61" D 2,39 cm / .94"		H 43,6 cm / 17.17" D 35 cm / 13.78"
Clip W 4,17 cm / 1.64"			H 17,15 cm / 6.75" D 35 cm / 13.78"
Shelf (for modules w. door) W 39,7 cm / 15.63"	H 1,05 cm / .41" D 28,7 cm / 11.3"	Podium w. Tube Base W 130,8 cm / 51.5"	H 9,8 cm / 3.86" D 35 cm / 13.78"
Insert (for open and modules w. back) W 39,6 cm / 15.59"		Podium w. Tube Base W 43,6 cm / 17.17"	H 9,8 cm / 3.86" D 35 cm / 13.78"
Top Plate L 130,8 cm / 51.5"		Plinth W 130,8 cm / 51.5"	H 9,8 cm / 3.86" D 35 cm / 13.78"
Top Plate L 43,6 cm / 17.17"		Plinth W 43,6 cm / 17.17"	H 43,6 cm / 17.17" D 35 cm / 13.78"
		Small (Open or w. back) W 21,8 cm / 8.58"	H 43,6 cm / 17.17" D 35 cm / 13.78"
		Medium (Open or w. back) W 43,6 cm / 17.17"	H 43,6 cm / 17.17" D 35 cm / 13.78"
		Large (Open or w. back) W 65,4 cm / 25.75"	H 43,6 cm / 17.17" D 35 cm / 13.78"
		Medium w. Door W 43,6 cm / 17.17"	H 65,4 cm / 25.75" D 35 cm / 13.78"
		Large w. Door W 43,6 cm / 17.17"	H 17,15 cm / 6.75" D 35 cm / 13.78"

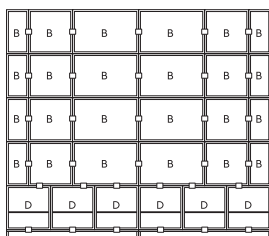

Bookcase 1

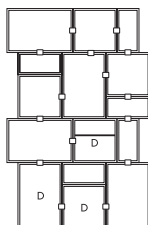

2

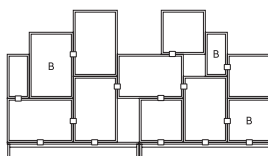

3

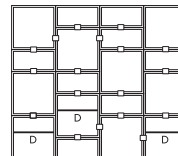

4

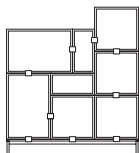

5

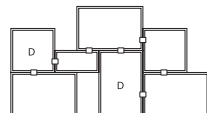

6

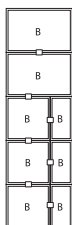

7
(Wall-mounted)

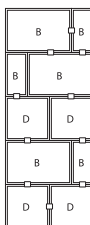

8

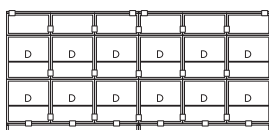

Sideboard 1

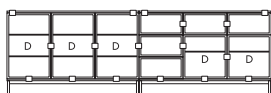

2

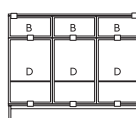

3

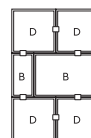

4

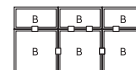

5
(Wall-mounted)

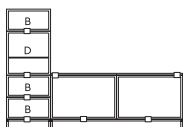

Hallway 1

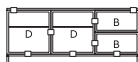

2

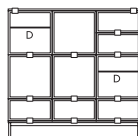

3



4
(Wall-mounted)

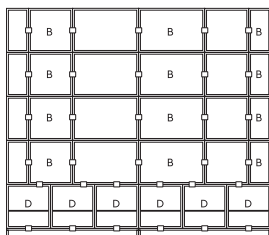

Office 1

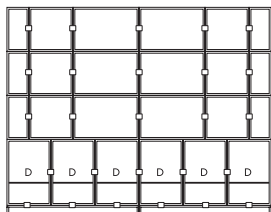

2

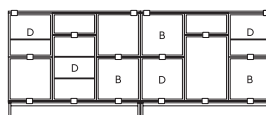

3



4



5



Bedside 1



2

B = module w. backboard
D = module w. door

Shelves, indicated with lines on the drawings, can be positioned in two fixed positions inside modules w. door. Optional inserts can be placed in open modules and modules w. backboard. Clips must be placed according to our assembly guidelines to suit your preferences. The illustrations of clips are for visual reference only. All standard configurations are tested according to European standard EN 16121:3013+A1:2017 Test Severity 2. Please follow assembly rules and configuration guidelines when building your Stacked configuration.

Inspiration for your Stacked Storage System

Choose from 24 pre-designed configurations or design your own Stacked Storage System on planner.muuto.com.

Mini Stacked Storage System



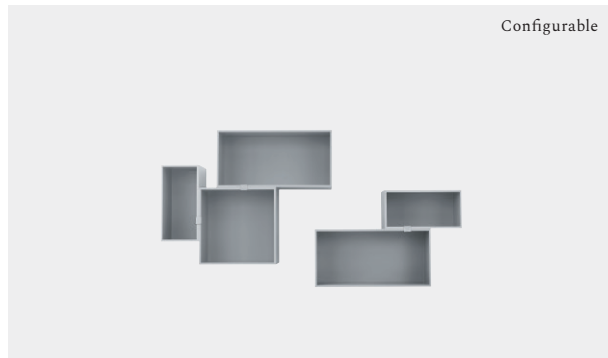

by Julien De Smedt



Material

Modules in PU lacquered MDF or Oak veneered fiberboard. Clips are powder-coated bent steel with rubber inserts. Lacquered versions: Every side is cut out of MDF, glued together, and painted with three layers of PU lacquer. Oak versions: Every side is cut out of fiberboard with oak veneer and glued together.

Ready-To-Ship Options

Oak	
White	
Grey	
Brown Green	

Additional information

Each Mini Stacked Storage System module comes with one matching clip, while Oak comes with a Grey clip. Extra clips can be purchased separately.

	H 24,9 cm / 9,75"
Large W 49,8 cm / 19.5" D 26 cm / 10.25"	
	H 33,2 cm / 13"
Medium W 33,2 cm / 13" D 26 cm / 10.25"	
	H 16,6 cm / 6.5"
Small W 33,2 cm / 13" D 26 cm / 10.25"	
	H 2,5 cm / 1"
Clip W 2,5 cm / 1" D 1,6 cm / 0.5"	



Config. 1



Config. 2



Config. 3



Config. 4



Config. 5

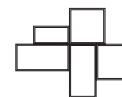

Config. 6



Config. 7



Config. 8

Inspiration for your Mini Stacked Storage System

Choose from our pre-designed configurations or design your own Mini Stacked Storage System on planner.muuto.com. Clips are not shown on the drawings. Please follow assembly instructions and configuration guidelines.

Compile Shelving System
by Cecillie Manz

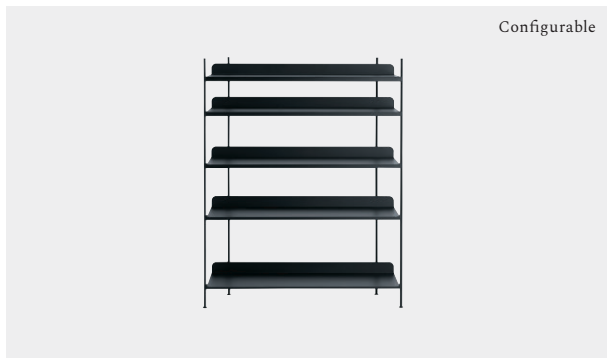

Material
Powder-coated steel.

Ready-To-Ship Options

- Black

- Grey

- White



Shelf
W 120 cm / 47.25"

D 42 cm / 16.5"

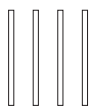

39 cm / 15.5"

Dividers - Large



28.5 cm / 11.2"

Dividers - Medium



18 cm / 7.1"

Dividers - Small



H 11.6 cm / 4.6"
H 11 cm / 4.3"

Essentials Pack

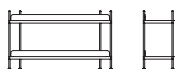

Config. 1

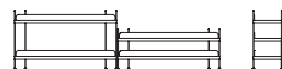

Config. 5

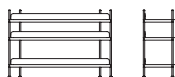

Config. 2

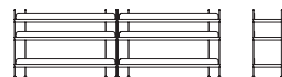

Config. 6

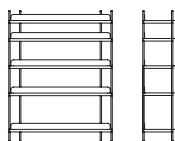

Config. 3

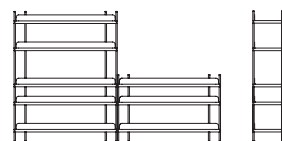

Config. 7

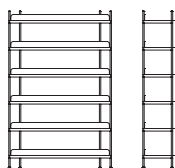

Config. 4

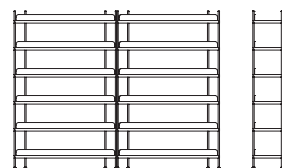

Config. 8

Inspiration for your Compile Shelving System
Choose from 8 pre-designed configurations or build your own Compile Shelving System by choosing from the different components.

Reflect Sideboard
by Søren Rose Studio



Material
Board with oak veneer and solid oak legs.

Ready-To-Ship Options
Oak

Black



Enfold Sideboard
by Thomas Bentzen



Material
Body, shelves and sliding doors in powder-coated bent steel. Top and base in solid oak treated with a clear oil (Size 186 x 45 H:48 cm and 148 x 45 H:85 cm as well as all sizes in Oak / Deep Red) or matte clear lacquer for other variants. Adjustable feet.
Size 186 x 45 H:48 cm and 148 x 45 H:85 cm as well as all sizes in Oak / Deep Red are FSC™-certified.

Ready-To-Ship Options
Oak / Grey

Oak / Dusty Green

Oak / Anthracite Black

Black / Anthracite Black

Oak / Deep Red

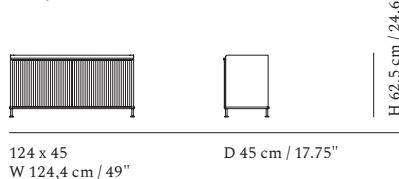
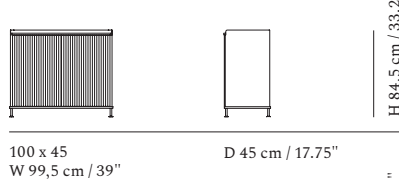
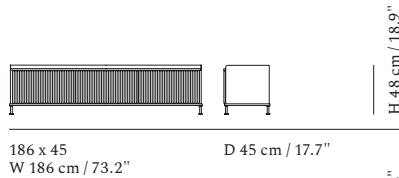
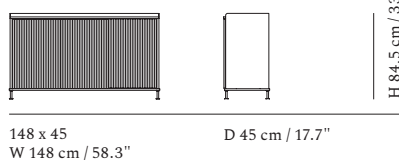

Flow Trolley
by Normal Studio



Material
Trays and legs in powder-coated steel. Wheels in powder-coated steel and rubber.

Ready-To-Ship Options
Grey

Blue-Grey

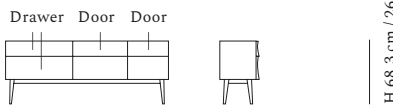

Large
W 180 cm / 70.9"

D 43,4 cm / 17.1"



Small
W 105,4 cm / 41.5"

D 43,4 cm / 17.1"



3-Layer
W 57,4 cm / 22.6"

D 41,8 cm / 16.4"



2-Layer
W 54,4 cm / 22.6"

D 41,8 cm / 16.4"

Lighting



Strand Pendant Lamp



Rime Pendant Lamp



Ambit Pendant Lamp

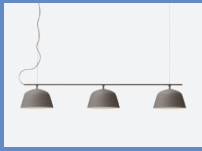

Ambit Rail Lamp



Top Pendant Lamp



Grain Pendant Lamp



Under the Bell
Pendant Lamp

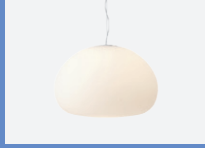

Fluid Pendant Lamp



Unfold Pendant Lamp



E27 Pendant Lamp



Fine Suspension Lamp

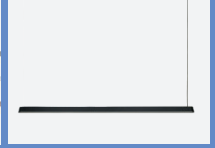

Linear Pendant Lamp



Linear Table Lamp



Set Table Lamp

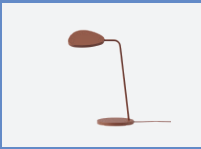

Leaf Table Lamp



Beam Table Lamp



Control Table Lamp



Cosy in Grey Table Lamp



Piton Portable Lamp



Ease Portable Lamp



Strand Table Lamp



Post Table Lamp



Tip Table Lamp



Dedicate Table Lamp



Dedicate Wall Lamp



Calm Wall Lamp

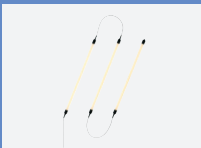

Fine Wall/Ceiling Lamp



Ambit Wall Lamp

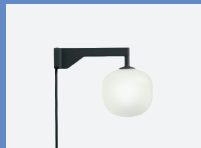

Rime Wall Lamp

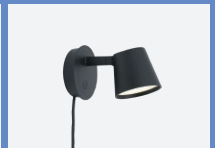

Tip Wall Lamp

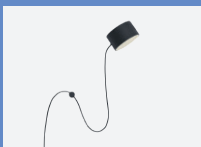

Post Wall Lamp

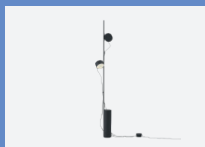

Post Floor Lamp

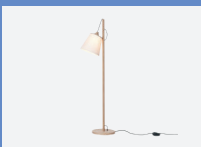

Pull Floor Lamp

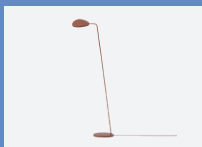

Leaf Floor Lamp

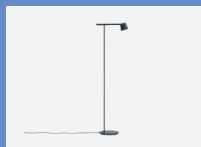

Tip Floor Lamp

Strand Pendant Lamp
by Benjamin Hubert



Material
Steel structure covered with cocoon material. PVC cord, PVC covered steel wire.

Ready-To-Ship Options
White

Light Source
Ø45, Ø60 & Ø80 1x E26/E27 Max. 60W
Ø28 & Ø40 1x E26/E27 Max. 40W

Rime Pendant Lamp
by TAF Studio



Material
Mouth-blown glass shade, aluminum, powder-coated top-piece and pendant tube, PVC cord.

Ready-To-Ship Options
White
Black
Grey
Orange
Deep Red

Light Source
Ø45 & Ø37 1x E26/E27 Max. 60W
Ø25 1x E12/E14 Max. 40W
Ø12* & Ø18* 1x G9 Max 25W
*EU version includes 3W frosted LED bulb

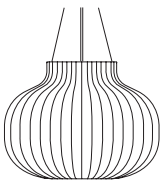

H 60.8 cm / 23.9"

Closed Ø 80 cm / 31.5"

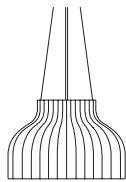

H 40.3 cm / 15.9"

Open Ø 60 cm / 23.6"

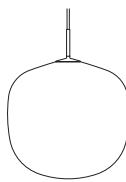

H 55.5 cm / 21.9"

Ø 45 cm / 17.7"



H 54.8 cm / 21.6"

Closed Ø 60 cm / 23.6"

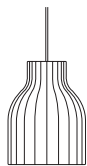

H 50.2 cm / 19.8"

Open Ø 40 cm / 15.7"

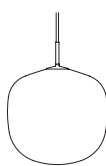

H 45.5 cm / 17.9"

Ø 37 cm / 14.6"



H 22 cm / 8.7"

Ø 18 cm / 7.1"

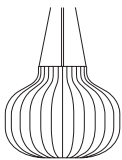

H 36.4 cm / 14.3"

Closed Ø 45 cm / 17.7"



H 37.4 cm / 14.7"

Open Ø 28 cm / 11"

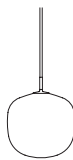

H 30 cm / 11.8"

Ø 25 cm / 9.8"



H 15 cm / 5.9"

Ø 12 cm / 4.7"

Ambit Pendant Lamp by TAF Studio



Material

Handspun and handpainted aluminum shade, PVC cord.

Ready-To-Ship Options

White	<input type="radio"/>
Black	<input type="radio"/>
Grey	<input type="radio"/>
Taupe	<input type="radio"/>
Light Blue	<input type="radio"/>
Dusty Green	<input type="radio"/>
Rose (Only available in Ø40 cm)	<input type="radio"/>

Light Source

Ø55 & Ø40 1x E26/E27 Max. 60W

Ø25 1x E12/E14 Max. 60W

Ø16,5* 1x GX53 Max. 12W LED

*EU version includes 5,5W frosted LED bulb

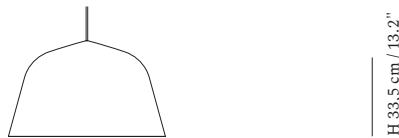

Ø 55 cm / 21.7"

H 33,5 cm / 13.2"



Ø 40 cm / 15.7"

H 23,8 cm / 9.4"



Ø 25 cm / 9.8"

H 15 cm / 5.9"



Ø 16,7 cm / 6.6"

H 9,8 cm / 3.9"

Ambit Rail Lamp by TAF Studio

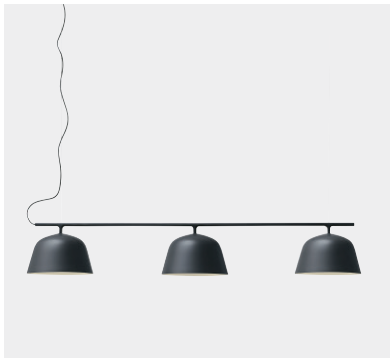

Material

Cast and extruded aluminum, handspun aluminum, PVC cord, steel wires.

Ready-To-Ship Options

White	<input type="radio"/>
Black	<input type="radio"/>
Grey	<input type="radio"/>
Taupe	<input type="radio"/>
Dusty Green	<input type="radio"/>

Light Source

3 x E14/E12 Max. 60W



L 126 cm / 49.6"

H 19,7 cm / 7.8"

Top Pendant Lamp by Big-Game



Material

Spun steel shade with a high gloss wet paint finish. PVC cord. Socket in nylon.

Ready-To-Ship Options

Sand	<input type="radio"/>
Grey	<input type="radio"/>
Deep Red	<input type="radio"/>
Dark Green	<input type="radio"/>

Light Source

Ø38 & Ø28 Max. 9W; Self ballasted LED bulb. 1x

GX53 light bulb included

Ø36 & Ø21 Max. 5W; Self ballasted LED bulb. 1x

GX53 light bulb included



Ø 38 cm / 15"

H 26 cm / 10.2"



Ø 36 cm / 14.2"

H 12 cm / 4.7"

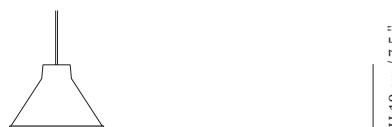

Ø 28 cm / 11"

H 19 cm / 7.5"



Ø 21 cm / 8.3"

H 13 cm / 5.1"

Grain Pendant Lamp
by Jens Fager



Material
Mixture of bamboo fibers and plastic, PVC cord.

Ready-To-Ship Options

- Black ●

- Grey ●

- Dusty Green ●

- Dark Green ●

- Blue-Grey ●

- Nature ●

Light Source
1x G9 Max. 5W LED
3W LED bulb included

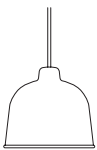

Ø 21 cm / 8.3"

H 18.5 cm / 7.3"

Under The Bell Pendant Lamp
by Iskos-Berlin



Material
PET felt made from up to 41% recycled plastic, PVC cord.

Ready-To-Ship Options

- Black ●

- Grey ●

- White Melange ●

- Dark Green ●

Light Source
1x E26/E27 Max. 60W

Made with recycled materials



Ø 82 cm / 32.3"

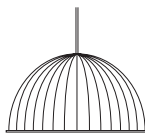

Ø 55 cm / 21.7"

H 46 cm / 18.1"

H 31 cm / 12.2"

Fluid Pendant Lamp
by Claesson Koivisto Rune



Material
Silk matt opal glass, PVC cord, metal wire.

Ready-To-Ship Options

- White ●

Light Source
Large 1x E26/E27 Max. 60W
Small* 1x G9 Max. 40W
*1x 3W LED bulb included



Ø 42 cm / 16.5"



Ø 23 cm / 9"

H 27 cm / 10.5"

H 14.3 cm / 5.5"

Unfold Pendant Lamp by Form Us With Love



Material
Silicone rubber, PC plastic diffuser.

Ready-To-Ship Options

White	<input type="radio"/>
Black	<input type="radio"/>
Dark Grey	<input type="radio"/>
Light Grey	<input type="radio"/>
Mustard	<input type="radio"/>
Terracotta	<input type="radio"/>
Orange	<input type="radio"/>
Green	<input type="radio"/>
Olive	<input type="radio"/>
Dark Brown	<input type="radio"/>
Light Yellow	<input type="radio"/>

Light Source

1x E26/E27 Max. 60W

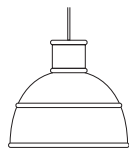

Ø 32,5 cm / 12.8"

H 29,5 cm / 11.6"

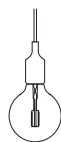

Ø 12,5 cm / 5"

H 23 cm / 9"

E27 Pendant Lamp by Mattias Ståhlbom



Material
Silicone rubber.

Ready-To-Ship Options

Black	<input type="radio"/>
Light Grey	<input type="radio"/>
White	<input type="radio"/>
Light Green	<input type="radio"/>
Olive	<input type="radio"/>
Beige Green	<input type="radio"/>
Dark Green	<input type="radio"/>
Light Blue	<input type="radio"/>
Pale Blue	<input type="radio"/>
Midnight Blue	<input type="radio"/>
Dusty Lilac	<input type="radio"/>
Deep Red	<input type="radio"/>
Light Orange	<input type="radio"/>

Light Source

1x E26/E27 Max. 40W
2W LED bulb included

Fine Suspension Lamp by TAF Studio



Material

Body in pressure-die casted and extruded, powder-coated aluminum. Diffuser in extruded opaque plastic. Lamp driver integrated in white plastic canopy. We recommend that any tasks related to high-voltage systems only be performed by a licensed electrical contractor.

Ready-To-Ship Options

Black	<input type="radio"/>
Grey	<input type="radio"/>
Deep Red	<input type="radio"/>

Light Source

60 cm—15W integrated, dimmable, non-user replaceable LED module designed for Right to Repair, meaning that light source can be replaced by an electrician only.

90 cm—20W integrated, dimmable, non-user replaceable LED module.

120 cm—25W integrated, dimmable, non-user replaceable LED module.



L 120cm / 47.2"
D 2,4 cm / 0.9"

H 1,8 cm / 0.7"



L 90cm / 35.4"
D 2,4 cm / 0.9"

H 1,8 cm / 0.7"

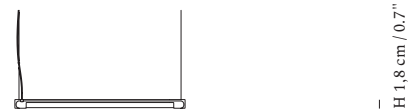

L 60 cm / 23.6"
D 2,4 cm / 0.9"

H 1,8 cm / 0.7"

Linear Pendant Lamp by Thomas Bentzen

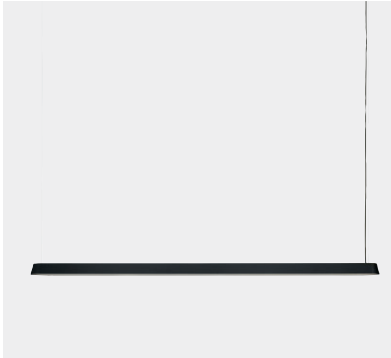

Material

Lamphead in pressure-die casted and extruded, powder-coated aluminum. Stem in powder-coated steel. Diffuser in polycarbonate. PVC cord.

Ready-To-Ship Options

Black



Grey



Light Source

87,2 cm 20,3W integrated LED
169,2 cm 37,7W integrated LED

Linear Table Lamp by Thomas Bentzen



Material

Lamphead in powder-coated, pressure die-casted aluminum. Stem in powder-coated steel. Polycarbonate diffuser and PVC cord.

Ready-To-Ship Options

Black



Grey



Light Source

6,25W integrated LED, dimmable
Built-in 18W USB-C plug

Set Table Lamp by Jamie Wolfond



Material

The lamp body and shade are in anodized aluminum. The underside of the shade is powder-coated aluminum. Light can be controlled using the inline dimmer or rotating the lamp shade.

Ready-To-Ship Options

Aluminum



Light Source

18W integrated, dimmable, and non-user replaceable LED light designed for Right to Repair.



L 169,2 cm / 66.6"

H 5,4 cm / 2.1"

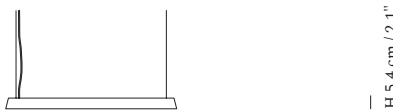

H 5,4 cm / 2.1"

L 87,2 cm / 34.3"



W 23,2 cm / 9.1"

H 36,5 cm / 14.4"

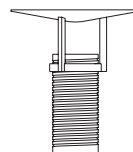

Ø 34 cm / 13.39"

H 37,9 cm / 14.92"

Leaf Table Lamp
by Broberg & Ridderstråle



Material
Pressure die-casted aluminum, PVC cord.

Ready-To-Ship Options

White	<input type="radio"/>
Black	<input type="radio"/>
Grey	<input type="radio"/>
Dark Green	<input type="radio"/>
Copper Brown	<input type="radio"/>

Light Source
8W integrated LED, dimmable

Beam Table Lamp
by Tom Chung



Material
Extruded anodized aluminum, PVC cord.

Ready-To-Ship Options

Black	<input type="radio"/>
Aluminium	<input type="radio"/>
Green	<input type="radio"/>
Umber	<input type="radio"/>

Light Source
10W integrated LED, dimmable

Control Table Lamp
by TAF Studio



Material
Casted aluminum, PVC cord.

Ready-To-Ship Options

White	<input type="radio"/>
Black	<input type="radio"/>
Grey	<input type="radio"/>
Red	<input type="radio"/>

Light Source
1x E26/E27 Max. 40W
Light source must be dimmable
2W LED bulb included, dimmable



W 18 cm / 7"
Shade 15,5 x 18,5 cm / 6" x 7.25"

H 41,5 cm / 16.25"

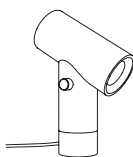

W 18,7 cm / 7.4"

H 26,2 cm / 10.3"

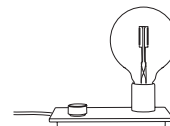

W 21 cm / 8.3
D 14 cm / 5.5"

H 21,5 cm / 8.5"

Cosy In Grey Table Lamp
by Harri Koskinen



Material

Soda lime glass, transparent PVC cord with a dimmer, plastic socket and an internal clear plastic construction to secure cord and socket.

Ready-To-Ship Options

Grey



Light Source

1 x E27Max. 60W

Light source must be dimmable

Piton Portable Lamp
by Tom Chung



Material

Battery-powered portable lamp with 6 hours of battery-life at maximum brightness. Body in anodized extruded aluminum. Lamp shade in injection molded plastic. Woven fabric USB-C cable.

Ready-To-Ship Options

Black



Aluminum



Light Source

3,2W integrated, replaceable LED module, dimmable

Ease Portable Lamp
by Johan Van Hengel



Material

Battery-powered portable lamp with 8 hours of battery-life at maximum brightness. Body and lampshade made in injection-molded ABS plastic, with an integrated LED light source. Diffuser in opal acrylic. Charging dock made in injection-molded ABS plastic with USB-C cable.

Ready-To-Ship Options

Black



Grey



Light Blue



Taupe



Light Source

4W integrated, non-replaceable LED module, dimmable

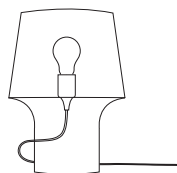

H 32,4 cm / 12.7"

W 23,2 cm / 9.1"

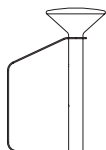

H 21,8 cm / 8.6"

W 32,1 cm / 12.6"
D 13,2cm / 5.2"

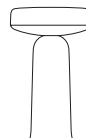

H 21,5 cm / 8.46"

W 13,16 cm / 5.18"

Strand Table Lamp
by Benjamin Hubert



Material
Cocoon layer with inner steel structure, base in iron and aluminum, PVC cord with inline dimmer.

Ready-To-Ship Options

White



Light Source

EU/US: E27/E26, max. 13W SBLED. Light Source not included. Recommended light source: Type G80, Ø80 x 115 mm, E27/E26, 8W frosted LED. Light source must be dimmable.

Post Table Lamp
by Earnest Studio



Material
Base in powder coated steel. Lighting unit in powder coated magnesium with silicone cord and opal diffuser. Cable drops in ABS with magnet. Power supply with ABS connector and PVC cord.

Ready-To-Ship Options

Black



Brown Green



Light Source

6,7W non-replaceable LED modules, dimmable.

Tip Table Lamp
by Jens Fager



Material
Pressure die-casted aluminum, PVC cord.

Ready-To-Ship Options

White



Black



Grey



Copper Brown



Light Green



Light Source

8W integrated LED, dimmable.

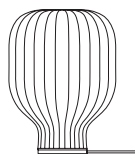

Ø 29 cm / 11.4"

H 39 cm / 15.4"



W 9,5 cm / 3.7"
Lighting unit Ø 9,5 cm / 3.7"

H 45,2 cm / 17.8"



Ø 16 cm / 6.3"
W 29,5 cm / 11.6"

H 40 cm / 15.7"

Dedicate Table Lamp
by Thomas Bentzen



Material
The lamp head and hinges are in die-casted aluminum, and the lamp arms are in extruded aluminum. All powder-coated. Diffuser in injection molded plastic. Table base in machined steel. Clamp in die-casted aluminum and screw in stainless steel.

Ready-To-Ship Options

Black

Brown Green

Light Source

14 W integrated dimmable LED. The lamp comes with a built-in 8-hour timer.

Dedicate Wall Lamp
by Thomas Bentzen



Material
Lamp head and hinges in die-casted aluminum, lamp arms in extruded aluminum. All powder-coated. Diffuser in injection molded plastic. Wall Mount in die-casted aluminum.

Ready-To-Ship Options

Black

Brown Green

Light Source

14 W integrated dimmable LED. The lamp comes with a built-in 8-hour timer.

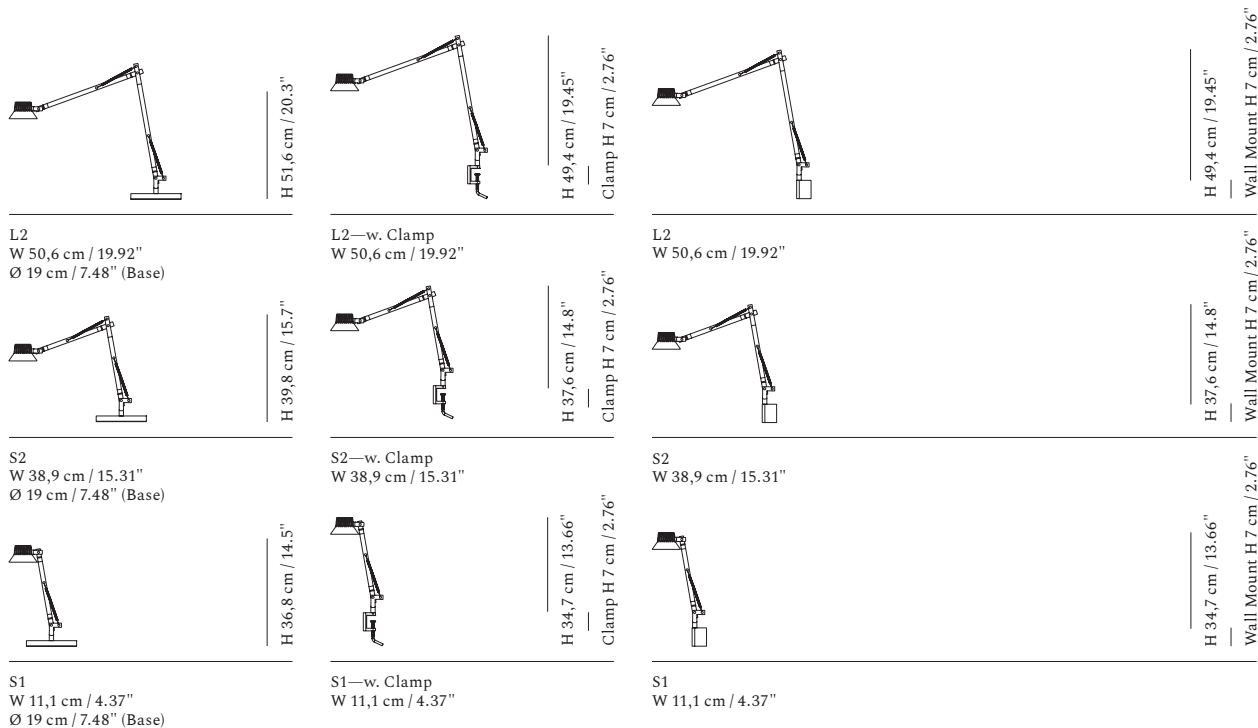

Fine Wall / Ceiling Lamp
by TAF Studio

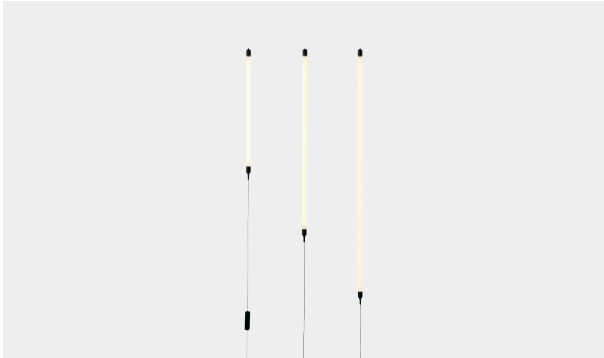

Material
Body in pressure-die casted and extruded, powder-coated aluminum. Diffuser in extruded opaque plastic. Single profiles come with an inline dimmer and plug. Configurations come with a wall/ceiling mounted driver integrated in white plastic driver box. Configurations are dimmable when hardwired—no dimmer on cable.

Ready-To-Ship Options
Black



Light Source
60 cm—15W integrated, dimmable, non-user replaceable LED module designed for Right to Repair, meaning that light source can be replaced by an electrician only.
90 cm—20W integrated, dimmable, non-user replaceable LED module.
120 cm—25W integrated, dimmable, non-user replaceable LED module.

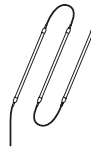

Configuration 1
C1

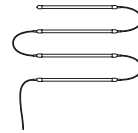

Configuration 2
A1

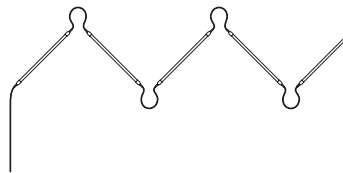

Configuration 3
D1



Configuration 4
B1



Configuration 5
B2



Configuration 6
A4



L 120cm / 47.2"
D 2,4 cm / 0.9"

H 1,8 cm / 0.7"



L 90cm / 35.4"
D 2,4 cm / 0.9"

H 1,8 cm / 0.7"

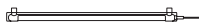

L 60 cm / 23.6"
D 2,4 cm / 0.9"

H 1,8 cm / 0.7"

Inspiration for your Fine Wall/Ceiling Lamp Configuration
Choose from 6 pre-made configurations that can be positioned in numerous playful ways.

Calm Wall Lamp by Aleksej Iskos

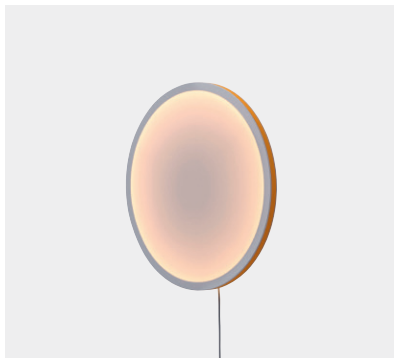

Material

Extruded aluminum profile, steel mounting plates. Injection molded ABS cover, soft diffusing textile shades (front and back). Integrated LED, that is temperature dimmable (dim to warmer lighting). Colored silicone band. Ø50 touch dim comes with a touch button and cable with a plug (no dimmer on the cable). All other sizes/variants come as hard-wired (Wall dim). Cord with inline dimmer and plug can be purchased separately and works for hard-wired versions.

Ready-To-Ship Options

White / Black



White / Grey



White / Orange



Light Source

Ø50—touch dim w. cord and plug; 19W integrated, dimmable non-replaceable LED module.

Ø50—19W integrated, dimmable, non-replaceable LED module.

Ø68—28W integrated, dimmable, non-replaceable LED module.

Ø90—35W integrated, dimmable, non-replaceable LED module.

Ambit Wall Lamp by TAF Studio

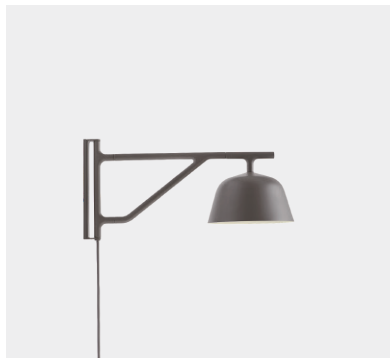

Material

The lampshade, arm fixture, and wall mount piece are made from aluminum and wet painted. The cord is made from PVC. An extra wall bracket is included in the Ambit Wall Lamp that allows for the wiring to be integrated into the wall.

Ready-To-Ship Options

White



Black



Grey



Taupe



Light Source

1x GX53 Max. 12W LED

EU version includes 5,5W frosted LED bulb



w. Touch Dim

Ø 50 cm / 19.6" — D 7,25 cm / 2.85"

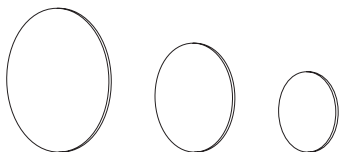

w. Wall Dim

Ø 50 cm / 19.6" — D 7,25 cm / 2.85"

Ø 68 cm / 26.7" — D 7,25 cm / 2.85"

Ø 90 cm / 35.4" — D 7,25 cm / 2.85"

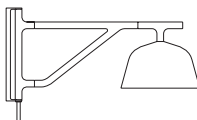

L 40,7 cm / 16"

Shade W 16,7 cm / 6.6"

H 19,5 cm / 7.7"

Rime Wall Lamp
by TAF Studio



Material

Shade in mouth-blown, sandblasted glass. Arm in pressure die-casted and powder-coated aluminum. Wall bracket in chrome-plated steel, PVC cord.

Ready-To-Ship Options

White	<input type="radio"/>
Black	<input type="radio"/>
Grey	<input type="radio"/>
Orange	<input type="radio"/>

Light Source

1x G9 Max. 25W
3W frosted LED bulb included, dimmable

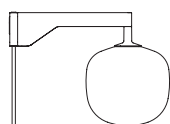

L 23 cm / 9.1"
Shade Ø 12 cm / 4.7"

H 16,2 cm / 6.4"

Tip Wall Lamp
by Jens Fager



Material

Powder-coated aluminum. PVC cord. Backplate in injection-molded plastic. Wall bracket in chrome steel.

Ready-To-Ship Options

White	<input type="radio"/>
Black	<input type="radio"/>
Grey	<input type="radio"/>
Copper Brown	<input type="radio"/>
Light Green	<input type="radio"/>

Light Source

8W integrated LED, dimmable



L 16 cm / 6.3"
Ø 9,5 cm / 3.7"

H 9,5 cm / 3.7"

Post Wall Lamp
by Earnest Studio



Material

Lighting unit in powder coated magnesium with silicone cord and opal diffuser. Wall mounting bracket in powder-coated steel. Wall cable drops in ABS with magnet and repositionable adhesive tape. Power hub in wet painted ABS with PCV cord.

Ready-To-Ship Options

Black	<input type="radio"/>
Brown Green	<input type="radio"/>

Light Source

6,7W integrated LED, dimmable

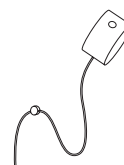

W 5,4 cm / 2.1"

H 9,5 cm / 3.7"

Post Floor Lamp
by Earnest Studio



Material

Base in powder coated steel. Lighting unit in powder-coated magnesium with silicone cord and opal diffuser. Cable drops in ABS with magnet. Power hub in wet painted ABS with PCV cord.

Ready-To-Ship Options

Black



Brown Green



Light Source

2x 6,7W non-replaceable LED modules, dimmable

Pull Floor Lamp
by Whatswhat



Material

Oiled Oak wood, 100% lined covered plastic shade, textile cord.

Ready-To-Ship Options

White / Oak



Light Source

1x E26/E27 Max. 60 W

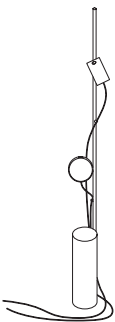

H 136,2 cm / 53,6"

W 9,5 cm / 3.7"
Lighting unit Ø 9,5 cm / 3.7"

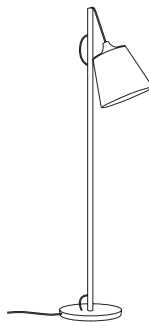

H 150 cm / 59"

W 31,5 cm / 12.4"
Shade Ø 27 cm H 24 cm / Ø 10.5" H 9.5"

Leaf Floor Lamp
by Broberg & Ridderstråle

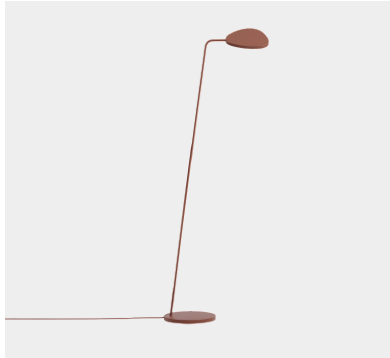

Material
Pressure die-casted aluminum, PVC cord.

Ready-To-Ship Options

White	<input type="radio"/>
Black	<input checked="" type="radio"/>
Dark Green	<input type="radio"/>
Copper Brown	<input checked="" type="radio"/>

Light Source
8W integrated LED, dimmable

Tip Floor Lamp
by Jens Fager



Material
Pressure die-casted aluminum, PVC cord.

Ready-To-Ship Options

White	<input type="radio"/>
Black	<input checked="" type="radio"/>
Grey	<input type="radio"/>

Light Source
10,9W integrated LED, dimmable

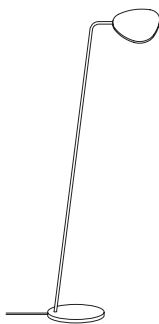

H 119 cm / 46.9"

W 22 cm / 8.7"
Shade 15,5 x 18,5 cm / 6" x 7.25"

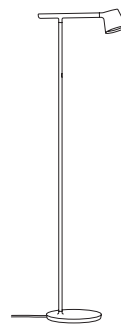

H 110,8 cm / 43.6"

W 32 cm / 12.6"
Foot Ø 20 cm / 7.9"

Accessories



Dots Wood Coat Hooks



Dots Metal Coat Hooks



Attach Coat Hook



Avail Coat Hook



Coil Coat Rack



Folded Shelves



Framed Mirror



Arced Mirror



Restore Basket



Restore Tray



Restore Round Basket

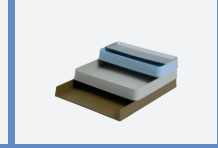

Arrange Desktop Series

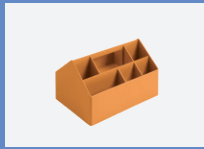

Sketch Toolbox



Reduce Paper Bin

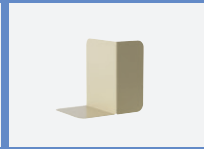

Compile Bookend



Story Pinboard



Raise Carafe & Glasses



Corky Carafe & Glasses



Platform Tray



Wave Tray



Mere Bowl



Kink Vase



Ridge Vase



Silent Vase



Ply Rug



Pebble Rug



Varjo Rug



Relevo Rug



Tile Cushion



Mingle Cushion

Dots Wood Coat Hooks by Lars Tornøe

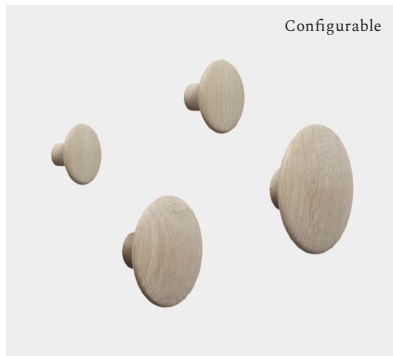

Material
Oak, ash or walnut. Colored versions in ash wood.

Additional Information

All colors available as single pieces. Oak, Black and Off-White available as Set of 5 including 1x Ø17, 1x Ø13 and 3x Ø9. Create playful and unique Dots compositions on planner.muuto.com.

Ready-To-Ship Options

Oak	
Ash	
Stained Dark Brown	
Off-White	
Black	
Grey	
Midnight Blue	
Pale Blue	
Dark Green	
Dusty Green	
Burgundy	
Taupe	
Sage Green	
Light Blue	
Burnt Orange	
Brown Green	

Dimensions
Ø 17 cm—6.75"
Ø 13 cm—5"
Ø 9 cm—3.5"
Ø 6,5 cm—2.5"

Dots Metal Coat Hooks by Lars Tornøe

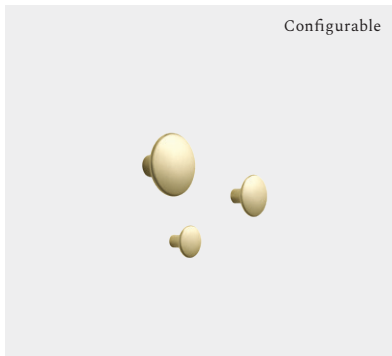

Material
Anodized solid aluminum.

Additional Information

All colors available as single pieces and as Set of 5 with 1x Ø5, 1x Ø3,9 and 3x Ø2,7. Create playful and unique Dots compositions on planner.muuto.com

Ready-To-Ship Options

Black	
Aluminum	
Pale Blue	
Dark Green	
Brass	
Umber	
Rose	
Taupe	
Lilac	
Light Green	

Dimensions
Ø 5 cm—2"
Ø 3,9 cm—1.5"
Ø 2,7 cm—1"

Attach Coat Hook by Dimitri Bähler



Material
Base in aluminum, hook in oak.

Ready-To-Ship Options

Oak / Black	
Oak / Aluminum	
Oak / Dark Green	
Oak / Burnt Orange	
Oak / Pale Blue	

Dimensions

W 5,1 cm / H 6,3 cm / Hook Ø 2,1 cm
W 2" / H 2.5" / Hook Ø 0.8"

Avail Coat Rack by Sam Hecht & Kim Colin



Material
Rack and dots in FSC™-certified oak that is either oiled or lacquered. Hooks in powder-coated steel.

Ready-To-Ship Options

Oak / Black



Oak / Copper Brown



Oak / Grey



Grey / Grey



Dimensions

L 87,5 cm / H Rack 7 cm / D 9,6 cm / Dots Ø 5,0 cm /
L 34.4" / H 2.7" / D 3.8" / Dots Ø 1.9" /

H Steel Hook: 14,5 cm—5.7"



The mark of
responsible forestry
FSC® C028624

Coil Coat Rack by Lars Tornøe



Material
Anodized aluminum.

Ready-To-Ship Options

Black



Plum



Dark Green



Dimensions

L 100 cm / H 9,5 cm / D 6,5 cm
L 39.4" / H 3.7" / D 2.6"

L 60 cm / H 9,5 cm / D 6,5 cm
L 23.6" / H 3.7" / D 2.6"

H Hook: 9 cm—3.5"

Folded Shelves by Johan van Hengel



Material
Acrylic powder-coated bended 1,5 mm sheet of steel.
Steel hooks.

Ready-To-Ship Options

Black



Grey



Blue-Grey



Olive



Burnt Orange



Deep Red



Dimensions

Shelves
W 96 cm / D 11,4 cm / H 13 cm
W 37.75" / D 4.5" / H 5"

W 63 cm / D 12,4 cm / H 16,5 cm
W 24.75" / D 4.75" / H 6.5"

W 51 cm / D 6,9 cm / H 22 cm
W 20" / D 2.75" / H 8.75"

W 29,5 cm / D 8 cm / H 40 cm
W 11.5" / D 3.1" / H 15.75"

Platform

W 62 cm / D 19 cm / H 5,4 cm
W 24.4" / D 7.48" / H 2.12"

Framed Mirror by Anderssen & Voll

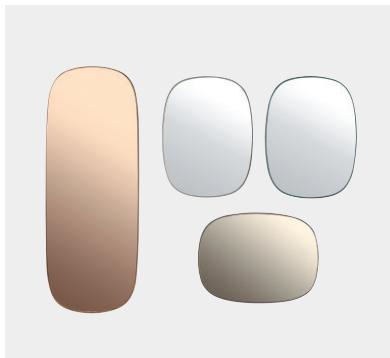

Material

Powder-coated steel, mirror glass sheet.

Ready-To-Ship Options

(Frame/Mirror Glass)

Grey / Clear



Taupe / Clear



Rose / Clear



Dark Green / Clear



Taupe / Taupe



Rose / Rose



Dimensions

Large

W 44,5 cm / H 118 cm / D 4 cm

W 17.5" / H 46.5" / D 1.5"

Small

W 44 cm / H 59 cm / D 4 cm

W 17.25" / H 23.25" D / 1.5"

Arced Mirror by Rhys Cooper

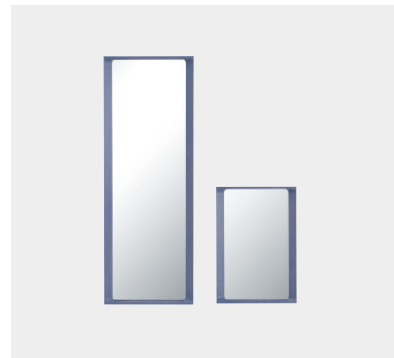

Material

Frame made from FSC™-certified spruce wood. Clear mirror glass. The spruce wood frame is treated with a wood stain color and finished with a clear matte lacquer. The backside is enclosed by a black backboard.

Ready-To-Ship Options

Light Grey



Light Green



Light Lilac



Dimensions

Large

W 55 cm / H 80 cm / D 5,10 cm

W 21.65" / H 31.5" / D 2.01"

Small

W 61 cm / H 170 cm / D 5,10 cm

W 24.02" / H 66.93" D / 2.01"



The mark of
responsible forestry
FSC® C028824

Restore Basket
by Mika Tolvanen



Material
Polymer PET felt.

Ready-To-Ship Options

- Black Melange ●

- Grey Melange ●

- Sand ●

- Dark Brown ●

- Burnt Orange ●

- Brown Green ●

- Dark Green ●

- Dusty Green ●

- Beige Green ●

- Midnight Blue ●

- Light Blue ●

- Dusty Lilac ●

Dimensions

W 35 cm / D 48 cm / H 23 cm
W 13.75" / D 19" / H 9"

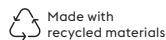

Restore Tray
by Mika Tolvanen



Material
Polymer PET felt.

Ready-To-Ship Options

- Black Melange ●

- Grey Melange ●

- Sand ●

- Brown Green ●

- Dusty Green ●

- Midnight Blue ●

- Light Blue ●

Dimensions

W 32 cm / D 39 cm / H 12 cm
W 12.5" / D 15.5" / H 4.75"

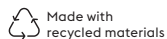

Restore Round Basket
by Mika Tolvanen



Material
Polymer PET felt.

Ready-To-Ship Options

- Black Melange ●

- Grey Melange ●

- Brown Green ●

- Dusty Green ●

- Midnight Blue ●

Dimensions

Ø 52 cm / H 23 cm
Ø 20.5" / H 9"

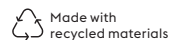

Arrange Desktop Series by Big-Game

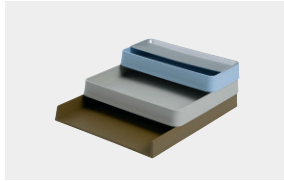

Material

Trays made using 100% recycled plastic. Lid in either cork or anodized aluminum.

Additional Information

Choose a pre-arranged configuration or build your own from single trays and lids. All tray sizes available in Grey; Light Blue and Brown Green in selected sizes.

Ready-To-Ship Options

(Trays)

Grey



Light Blue



Brown Green



(Lids)

Cork



Aluminum



Dimensions

Trays

W 25 cm / D 32 cm / H 3,5 cm
W 9.6" / D 12.6" / H 1.4"

W 25 cm / D 25 cm / H 3,5 cm
W 9.6" / D 9.6" / H 1.4"

W 25 cm / D 12 cm / H 3,5 cm
W 9.6" / D 4.7" / H 1.4"

Lids

W 12 cm / D 24 cm / H 1 cm
W 4.7" / D 9.4" / H 0.4"

W 24 cm / D 8 cm / H 0,2-1 cm
W 9.4" / D 3.1" / H 0.4"

Config. 1

W 25 cm / D 32 cm / H 11 cm
W 9.6" / D 12.6" / H 4.3"

Config. 2

W 25 cm / D 32 cm / H 10 cm
W 9.6" / D 12.6" / H 3.9"

Made with recycled materials

Sketch Toolbox by Thomas Bentzen



Material

Produced using minimum 100% recycled ABS plastic from post-consumer waste.

Ready-To-Ship Options

Grey



Midnight Blue



Burnt Orange



Dimensions

W 26 cm / D 17,5 cm / H 16,5 cm
W 10.2" / D 6.9" / H 6.5"

Made with recycled materials

Reduce Paper Bin by Studio Tolvanen



Material

100% recycled ABS plastic from post-consumer waste.

Additional Information

Reduce Paper Bin has a 14 litre / 3.7 gallons capacity.

Ready-To-Ship Options

Anthracite



Grey



Light Green



Dark Red



Dimensions

W 31,9 / D 23,6 cm / H 36 cm
W 12.6" / D 9.3" / H 14.2"

Made with recycled materials

Compile Bookend by Cecilie Manz



Material

Powder-coated steel.

Ready-To-Ship Options

Grey



Plum



Beige-Green



Dimensions

W 15 cm / D 20 cm / H 19,5 cm
W 6" / D 8" / H 7.75"

Story Pinboard by Big-Game



Material

Cork.

Ready-To-Ship Options

Cork



Dimensions

W 28,5 cm / D 9 cm / H 21,7 cm
W 11.2" / D 3.5" / H 8.5"

Raise Carafe & Glasses by Broberg & Ridderstråle



Material
Mouth-blown glass.

Ready-To-Ship Options
Clear

Burnt Orange

Dark Blue

Dimensions
Carafe

Ø bottom 11 cm / H 22 cm / Vol. 1 liter
Ø 4.3" / H 8.7" / Vol. 33.8 oz

Glass 20 cl

Ø 5,3 cm / H 8 cm / 200 ml
Ø 2.1" / H 3.1" / 6.75 oz.

Glass 30 cl

Ø 5,3 cm / H 10,5 cm / 300 ml
Ø 2.1" / H 4.1" / 10 oz.

Corky Carafe & Glasses by Andreas Engesvik



Material
Glass, cork.

Ready-To-Ship Options
Clear

Grey

Dimensions
Carafe

Ø 9,9 cm / H 22,1 cm / Vol. 1 liter
Ø 4" / H 8.75" / Vol. 33.8 oz

Glass Low

Ø 8,5 cm / H 6 cm / 200 ml
Ø 3.4" / H 2.4" / 6.75 oz.

Glass Tall

Ø 8,5 cm / H 10 cm / 350 ml
Ø 3.4" / H 4" / 11.83 oz.

Platform Tray by Sam Hecht & Kim Colin



Material
Tray in ABS, insert in laminated oak veneer.

Ready-To-Ship Options
Grey

Blue-Grey

Dark Green

Dark Red

Dimensions

Ø 30 cm / H 7,2 cm—Ø 11.75" / H 2.75"

Wave Tray by Cara \ Davide

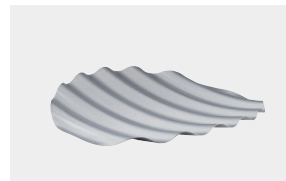

Material
Stainless steel.

Ready-To-Ship Options
Stainless Steel

Dimensions

Ø 50 cm / H 4 cm —Ø 19.7" / H 1.57"

Mere Bowl by Studio Kaksikko



Material
Ceramic stoneware with a high gloss glaze inside & out. The production process makes each bowl unique with small deviations in color, thickness and surface.

Ready-To-Ship Options
Brown Green

Off-White

Light Green

Dimensions

W 51,5 cm / D 21,5 cm / H 7,5 cm
W 20.28" / D 8.46" / H 2.95"

W 52 cm / D 36 cm / H 8 cm
W 20.47" / D 14.17" / H 3.15"

Kink Vase by Earnest Studio



Material
Pigmented porcelain. Glazed on the inside and raw on the outside. Small variations in the surface and color of the object are a natural and unique trait of the material.

Ready-To-Ship Options
Sand

Light Blue

Dusty Lilac

Dimensions

W 27,4 cm / D 12,9 cm / H 26,3 cm
W 10.8" / D 5" / H 10.3"

Ridge Vase by Studio Kaksikko



Material
Terracotta version made from terracotta. Off-White and beige version made from earthenware. Glazed inside and raw outside.

Ready-To-Ship Options
Off-White

Beige

Terracotta

Dimensions

W 31 cm / D 10,5 cm / H 48,5 cm
W 12.2" / D 4.3" / H 19"

W 23 cm / D 8,5 cm / H 35 cm
W 9.2" / D 3.4" / H 13.8"

W 20 cm / D 6 cm / H 16,5 cm
W 7.9" / D 2.4" / H 6.5"

Silent Vase by Andreas Engesvik



Material
Mouth-blown glass, cut and polished.

Ready-To-Ship Options
Clear

Dark Green

Burnt Orange

Dimensions

Ø 20 cm / H 23 cm
Ø 7.9" / H 9"

Ø 15 cm / H 19 cm
Ø 6" / H 7.5"

Ø 11 cm / H 13,4 cm
Ø 4.25" / H 5.25"

Ply Rug
by Margrethe Odgaard

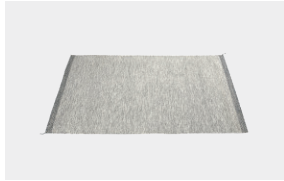

Material
100% New Zealand wool.

Additional Information

Size 270 x 360 cm is not available in Burnt Orange. Sizes 240 x 240 cm and 280 x 280 cm not available in Rose, Dark Grey and Midnight Blue.

Ready-To-Ship Options

- Rose 
- Dark Grey 
- Off-White 
- Black/White 
- Yellow 
- Midnight Blue 
- Burnt Orange 
- Light Rose 
- Grey 

Dimensions

W 360 cm / D 270 cm
W 11'8" / D 8'9"

W 300 cm / D 200 cm
W 9'8" / D 6'5"

W 280 / D 280 cm
W 9'2" / D 9'2"

W 240 / D 240 cm
W 7'9" / D 7'9"

W 240 cm / D 170 cm
W 7'9" / D 5'6"

W 200 cm / D 80 cm
W 6'5" / D 2'6"

W 140 cm / D 85 cm
W 4'6" / D 2'8"

Pebble Rug
by Margrethe Odgaard



Material
100% New Zealand wool. Backing in 100% cotton, pasted with synthetic latex.

Ready-To-Ship Options

- Pale Rose 
- Burnt Orange 
- Light Grey 
- Pale Blue 
- Brown Green 

Dimensions

W 300 cm / D 200 cm
W 9'8" / D 6'5"



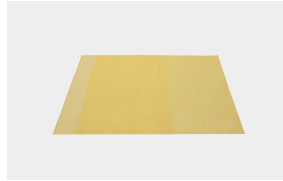

W 240 cm / D 170 cm
W 7'9" / D 5'6"

Varjo Rug
by Tina Ratzer



Material
100% New Zealand wool.

Ready-To-Ship Options

- Dark Grey 
- Dark Green 
- Blue 
- Yellow 

Dimensions

Width: 300 cm / 9'8"
Depth: 200 cm / 6'5"



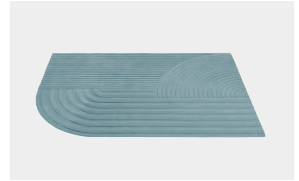

Width: 240 cm / 7'9"
Depth: 170 cm / 5'6"

Relevo Rug
by Studiopepe



Material
100% New Zealand Wool. Backing in 100% cotton, pasted with synthetic latex.

Ready-To-Ship Options

- Dark Green 
- Sage Green 
- Burnt Orange 
- Off-White 

Dimensions

W 300 cm / D 200 cm
W 9'8" / D 6'5"

W 240 cm / D 170 cm
W 7'9" / D 5'6"





Tile Cushion
by Anderssen & Voll



Material

Cover: 100% wool woven at Gudbrandsdalens Uldvarefabrik in Norway for Muuto. Filling: Mix of feather and polyester.

Ready-To-Ship Options

- Black/White 
- Green 
- Yellow 
- Tangerine 

Dimensions

W 45 cm / H 45 cm
W 17.7" / H 17.7"

Mingle Cushion
by Thomas Bentzen



Material

Cushion cover: Textiles Ecriture/Hero from Kvadrat. Inner sham: 55% polyester, 45% cotton. Fill: 100% polyester.

Ready-To-Ship Options

- Light Yellow 
- Light Green 
- Taupe 
- Midnight Blue 
- Light Blue / Mint 
- Sand / Lilac 
- Copper Brown / Light Blue 
- Rose / Petroleum 

Dimensions

W 55 cm / H 35 cm—W 21.7" / H 13.7"
W 45 cm / H 45 cm—W 17.7" / H 17.7"

find out more

Artworks

Abid Javed
 AKSO SCULPTURES
 Akua Objects
 Anja Thrane
 Anna Havskov
 Anne Mette My Paaske
 Argon Audio
 Aske Hagenboel
 Astrid Marie Christiansen
 Carla Freschi
 Casa Cubista
 Christina Ahm
 Christine Lyhne
 Elias Elias
 File under Pop
 Format Artspace
 Galerie Mikael Andersen
 Gesjæft
 Handmade By Marle
 Hanna Heino
 Jeba Arkitekt
 Jonas Sangberg
 Julie Damhus Studio
 Kia Handler Krøjgaard
 Kirsten Schrøder
 Kræsten Kusk
 Lene Winther
 Lille Nova
 Made By Chrillesen
 Marbless

Marbless Cph
 Maria Lenskjold
 Mermolja Keramik
 Meyer Lavigne
 Michael Chang
 Milla Glad
 Milla Vaahtera
 Muller Van Severen
 Nanna Gabriella
 Niko June
 Petersen Tegl
 Phanta
 Pia Eikaas
 Plakat Cph
 Rikke Hostrup
 Ruby Atelier
 Run Studio
 Shop Dora
 Simone Noa
 Skitse
 Søs Heidi Ravn
 Stine Bidstrup
 Stine Juul Studio
 Stine Regild
 Studio Reiser
 Tinne Maria Andersen
 Trine Bach
 Trine Bork

Photography

Petra Bindel
 Mikkel Tjellesen
 Benjamin Lund

Styling

Pernille Vest

Printing

Narayana Press, April 2024
 Subject to publisher's and
 printer's errors.

Downloads

Find more product information,
 product fact sheets, assembly instruc-
 tions, lifestyle images, packshots
 and much more on our download
 site download.muuto.com

Join Us

Sign up to our newsletter or
 follow us on social media to stay
 in the loop on new product releases,
 case stories, events and more.

muuto.com/newsletter-sign-up
instagram.com/muutodesign
pinterest.com/muuto
facebook.com/muuto
linkedin.com/company/muuto



Explore our catalog online.

Muuto Head Office
 Østergade 36-38
 DK-1100 Copenhagen,
 Denmark

For more information
 visit muuto.com

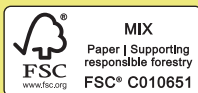

This catalog is printed on eco-friendly, high-quality paper in Denmark by Narayana Press.

Designers:

Aiayu
Aleksej Iskos
Anderssen & Voll
Andreas Bergsaker
Andreas Engesvik
Atelier BLI19
Benjamin Hubert
Big-Game
Broberg & Ridderstråle
CARA \ DAVIDE
Cecilie Manz
Claesson Koivisto Rune
David Geckeler
Dimitri Bähler
Earnest Studio
Form Us With Love
Hallgeir Homstvedt
Iskos-Berlin
Jamie Wolfond
Jens Fager
Johan Van Hengel
John Tree
Julien De Smedt
Lars Tornøe
Louise Campbell
Margrethe Odgaard
Mattias Ståhlbom
Mika Tolvanen
MSDS Studio
Normal Studio
Rhys Cooper
Sam Hecht & Kim Colin
Studio Kaksikko
Studiopepe
Sylvain Willenz
Søren Rose Studio
TAF Studio
Thomas Bentzen
Tina Ratzer
Tom Chung
WhatsWhat

